

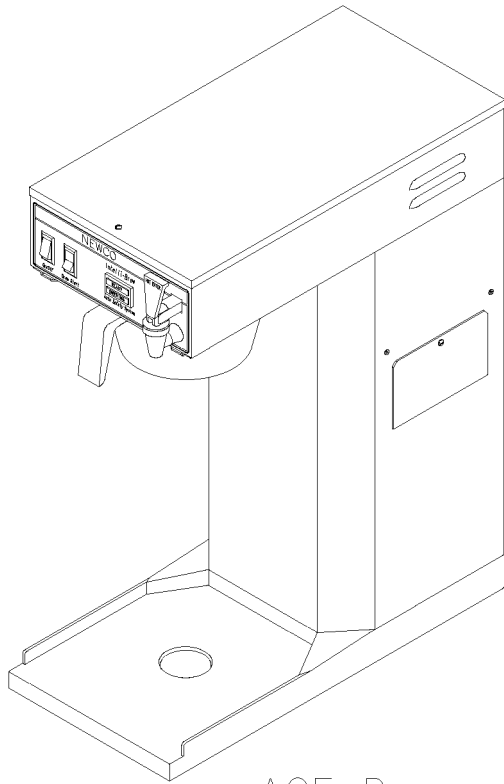

## INSTALLATION, OPERATION, AND SERVICE MANUAL FOR THE ACE SERIES - AUTOMATIC COFFEE EQUIPMENT

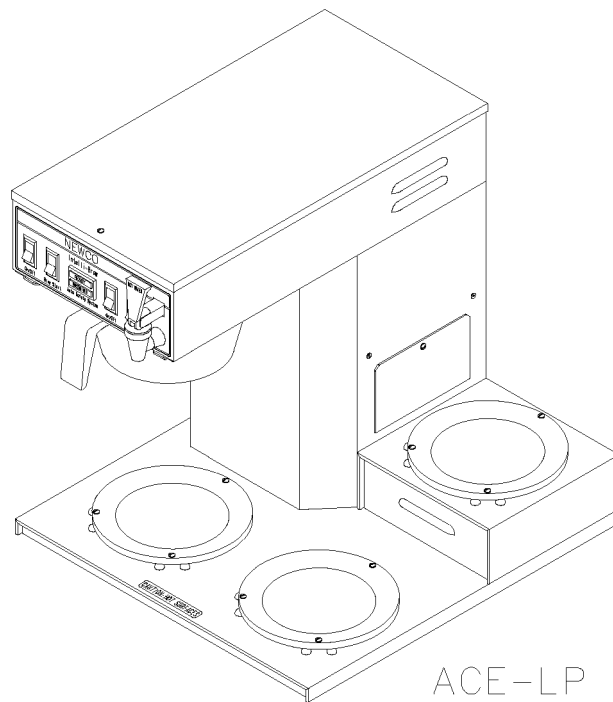

ACE-D



ACE-LP

Model	Warmers	Width	Depth	Height	Weight	120 V Watts		120 V Amps		240 V	
						US	Canada	US	Canada	Watts	Amps
ACE-S	3	8-1/2	16-1/2	17-7/16	29	1710	1410	14.3	11.8	3810	17.2
ACE-LP	3	15-1/2	16-1/2	15-7/8	31	1710	1410	14.3	11.8	3810	17.2
ACE-AP	0	8-1/2	17-11/16	22-1/4	29	1760	1410	14.7	11.8	3510	14.6
ACE-D	0	8-1/2	17-11/16	26-1/4	32	1760	1410	14.7	11.8	3510	14.6
ACE-TC	0	8-1/2	17-11/16	16-9/16	28	1760	1410	14.7	11.8	3510	14.6
ACE-LD	0	8-1/2	17-11/16	20-1/8	28	1760	1410	14.7	11.8	3510	14.6
ACE-TS	0	8-1/2	17-11/16	Varies	34	1760	1410	14.7	11.8	N/A	N/A

## ACE CONTROL OVERVIEW

The ace series brewers have been upgraded to include the “Super Ace” control. This control has all the features of the previous Ace control board with the additional options of pulse brewing, auto arm and half/full brew in one new compact control. These additional options may or may not be activated on your unit and may require additional parts. The following text outlines and explains the features and options.

### Features:

Digital technology – Gives more consistent brew cycle.

Live probe – This feature is activated when the hot water faucet is in use. When water reaches the water level probe it turns off the fill solenoid.

Overfill Protection - The Super Ace has a maximum fill valve run time of 1-1/2 minutes if the water does not contact the water level probe in the tank lid. This is intended to protect the unit from overflow should a fill error occur. When the tank is filling on the initial set up, an error will occur since this is not enough time to allow the tank to fill. This error will be indicated by a rapidly flashing brew light. The error may be cleared by holding down the brew start switch until the light stops flashing.

Visa-brew - This feature helps to communicate to the user that a brew cycle is in process. Once the brew cycle begins, the brewing lamp flashes to help prevent the removal of the brew basket or serving vessel prematurely. This feature is adjustable. Adjust the Visa-Brew time to allow sufficient time for hot beverage to drain from brew basket after completion of the water delivery portion of the brew cycle.

### Options:

Auto Arm - Pre-checks water temperature before brewing to ensure optimum brew temperature. When a brew cycle is initiated, the control board verifies that the temperature in the tank is equal to the thermostat setting. If the water temperature is not at proper temperature, the brew is stored in memory and light will flash to indicate brewing. When the temperature rises to the proper setting, the brewer will automatically begin to brew. If your brewer does not already have the auto arm feature the brewer will require additional parts and wiring changes to convert it.

Half brew – This option allows the brewer to brew a half or full decanter. This option will require additional parts and wiring changes. Basic kit part number is 120032.

Pulse brew - This option allows the brewer to turn the fill valve on and off during the brew cycle which extends water contact time with the coffee grounds. This option can be activated by moving the jumper designated (J1) from disabled to the enabled position. Basic kit part number is 108082.

**WARNING: - Read and follow installation instructions before plugging or wiring in machine to electrical circuit. Warranty will be void if machine is connected to any voltage other than that specified on the name plate.**

## Additional Options

PDS - The PDS flow control is an optional flow control valve that is more accurate than a traditional flow control over a wide range of water pressures and will maintain its volume setting for many years within the harsh water environment that coffee brewing equipment must operate. See pages 7 and 8 for additional information on this feature.

TS models – The Ace series brewer is available as a telescoping brewer. These brewers are equipped with a telescoping column to allow periodic adjustment of the brewer height. This feature allows continued use of the same piece of brewing equipment although the dispensers may change over time. See pages 9 and 10 for additional information on this feature.

## PLUMBER'S INSTALLATION INSTRUCTIONS

**CAUTION:** Power to brewer must be OFF before proceeding with plumbing installation.

1. Flush water line before installing brewer. Brewer should be connected to COLD WATER LINE only.
2. Water pressure should be at least 20 lbs. For less than a 25 ft run, use 1/4" copper tubing and connect to 1/2" or larger water line. For longer runs, use 3/8" copper tubing & connect to 1/2" or larger water line and provide an adapter fitting for connection to the brewer. Recommended flow rate from water line is 1 gpm.
3. If installed with saddle valve, the valve should have a minimum of 1/8" port hole for up to 25 ft run, and 5/16" port hole for over 25 ft runs.
4. Connect incoming water line to the elbow extending from the solenoid valve on the back of the brewer. Manufacturer recommends connecting to copper tubing.
5. Ensure that tank heater switch on the rear of brewer is in the off position. Connect brewer to appropriate electrical supply as indicated on serial tag.

## INSTALLATION INSTRUCTIONS

**FILL BREWER TANK WITH WATER BEFORE CONNECTING TO POWER SUPPLY !**

1. Place the decanter under brew basket, remove brewer top cover and tank lid and pour three decanters of water into the tank. Water should come through the brew basket as the third decanter empties of water. Re-install tank lid and top cover.
2. Plug or wire brewer to appropriate voltage circuit as indicated on serial tag. Turn (master / tank) switch (located in rear of equipment) to the ON position. Note: Brewer is shipped with thermostat turned on.
3. Place an empty decanter in position below the brew basket. With the decanter in place turn the lower warmer switch, power switch for dispenser models, to the ON position and depress brew start switch. When water begins to flow from the brew basket hold a suitable container beneath faucet and momentarily open the faucet to remove any entrapped air. Turn off lower warmer or power switch as applicable to cancel brew cycle.
4. Empty decanter and replace below the brewbasket. Turn on the lower warmer switch, power switch for dispenser models, and depress the brew start switch to begin a brew cycle, checking the volume of water delivered into decanter. Adjust timer to deliver desired amount of water. Turn timer dial clockwise to increase volume of water, counter clockwise to decrease it. On models with Auto-Arm brewer will not run until fully heated or if (master / tank) switch is turned off.
5. The brewing light located on the face of the machine below the ready light is part of the "Vis-A-Brew" safety system. This flashing amber light warns the user that hot liquid is draining from the brew funnel. This light should continue to flash until all liquid has drained into decanter. This control is preset at the factory but may be adjusted independent of the brew timer for your specific brewing conditions (i.e., filter type, coffee grind, etc.). Clockwise rotation of the knob will increase duration of the flashing while counterclockwise rotation will decrease the active time of the light. Both the timer and Vis-A-Brew adjustments are located behind the access panel on the side of the brewer except on telescoping models, where they are located below the top cover.
6. Allow 10 to 15 minutes for water in tank to heat to brewing temperature. After water has reached brewing temperature (thermostat will click off and green ready light will be lit) run one cycle to check for the proper temperature setting with an accurate thermometer. Take the temperature of this water at a point below the brew basket opening, at the start of the brew cycle and when the decanter is half full. Recommended temperature of the water is approximately 195 F. (Note: Brew cycle may be canceled by turning the rocker switch back to the OFF position.)
7. In higher altitude locations (5000 feet above sea level) the thermostat may have to be adjusted lower to prevent boiling.
8. **CAUTION:** The water faucet will dispense hot water when the handle is actuated. The faucet system may be operated during timed portion of brew cycle without yielding a short pot.

## COFFEE PREPARATION PROCEDURES

1. Place filter into brew basket.
2. Put the proper amount of coffee into the filter.
3. Slide the brew basket into holder.
4. Place the appropriate empty decanter into position below the brew basket. For airpots first open lid and remove pump stem. For other dispensers remove the lid unless it is a brew thru design. Turn lower warmer switch, or power switch for dispenser brewers, to the ON position.
5. Press brew start switch. (Brew cycle may be canceled by turning the rocker switch back to the OFF position.)
6. Hot water will be delivered through the sprayhead. This distributes the hot water evenly over the coffee bed within the brew basket. The coffee brew will drain from the brew basket into the decanter below.
7. The resultant coffee brew should be crystal clear and have the desired properties attainable through excellent extraction.
8. Turn off the warmer and power switches as applicable when not in use. Red light in switch indicates when power is on. Note: The solenoid will not run to replace water in tank that is drawn off from the faucet when the lower warmer switch, or power switch for dispenser models, is in the OFF position. However when the brew cycle is again initiated the tank will fill before cycle begins to prevent a short pot.
9. To clean brew basket simply remove from brew rails and dump filter into waste basket. The brewing process, as described above, can now be started again.

**LIMING:** To prevent liming problems in tank, sprayhead tubes, and vacuum breakers fittings remove sprayhead and insert deliming spring all the way into the tank. When inserted into tank properly, no more than ten inches of the spring should be visible at the sprayhead fitting. Saw back and forth five or six times. This will keep fittings open and clear of lime. In hard water areas this should be done everyday. This process takes approximately one minute. In all areas the sprayhead should be cleaned at least once a week. Where bad liming has already occurred, a new complete tank assembly may be installed.

# **WARRANTY**

**Applies to all equipment manufactured after 2/1/2017. This warranty supersedes all other previous warranties that are currently in manuals.**

**Newco warrants equipment manufactured by it for 1 year parts and labor.**

**Accessories and Dispensers 1 Year parts only.**

**Electronic Circuit and Control Boards- 3 years parts, 1 year labor.**

**Equipment manufactured by others and distributed by Newco- please see original equipment manufacturers warranty, Newco will follow.**

**These warranty periods run from the date of sale Newco warrants that the equipment manufactured by it will be commercially free of defects in material and workmanship existing at the time of manufacture and appearing within the applicable warranty period. This warranty does not apply to any equipment, component or part that was not manufactured by Newco or that, in Newco's judgment, has been affected by misuse, neglect, alteration, improper installation or operation, relocation or reinstallation, improper maintenance or repair, incorrect voltage applied to the unit at any time, damage or casualty. This warranty does not apply to any equipment failures related to poor water quality, excessive lime and chlorine and non periodic cleaning and descaling. Warranty is null and void if muriatic or any other form of hydrochloric acid is used for cleaning or deliming. In addition, this warranty does not apply to replacement of items subject to normal use including but not limited to user replaceable parts such as faucet seat cups, sight gauge tubes, washers, o-rings, tubing, seals and gaskets.**

**This warranty is conditioned on the Buyer 1) giving Newco prompt notice of any claim to be made under this warranty by telephone at (800) 556-3926 or by writing to 3650 New Town Blvd, Saint Charles, MO 63301; 2) if requested by Newco, shipping the defective equipment prepaid to an authorized Newco service location; and 3) receiving prior authorization from Newco that the defective equipment is under warranty.**

**THE FOREGOING WARRANTY IS EXCLUSIVE AND IS IN LIEU OF ANY OTHER WARRANTY, WRITTEN OR ORAL, EXPRESS OR IMPLIED, INCLUDING, BUT NOT LIMITED TO, ANY IMPLIED WARRANTY OF EITHER MERCHANTABILITY OR FITNESS FOR A PARTICULAR PURPOSE. The agents, dealers or employees of Newco are not authorized to make modifications to this warranty or to make additional warranties that are binding on Newco. Accordingly, statements by such individuals, whether oral or written, do not constitute warranties and should not be relied upon.**

**If Newco determines in its sole discretion that the equipment does not conform to the warranty, Newco, at its exclusive option while the equipment is under warranty, shall either 1) provide at no charge replacement parts and/or labor (during the applicable parts and labor warranty periods specified above) to repair the defective components, provided that this repair is done by a Newco Authorized Service Representative; or 2) shall replace the equipment or refund the purchase price for the equipment.**

**THE BUYER'S REMEDY AGAINST NEWCO FOR THE BREACH OF ANY OBLIGATION ARISING OUT OF THE SALE OF THIS EQUIPMENT, WHETHER DERIVED FROM WARRANTY OR OTHERWISE, SHALL BE LIMITED, AT NEWCO'S SOLE OPTION AS SPECIFIED HEREIN, TO REPAIR, REPLACEMENT OR REFUND.**

**In no event shall Newco be liable for any other damage or loss, including, but not limited to, lost profits, lost sales, loss of use of equipment, claims of Buyer's customers, cost of capital, cost of down time, cost of substitute equipment, facilities or services, or any other special, incidental or consequential damages.**

## TROUBLE SHOOTING GUIDE

SYMPTOM	POSSIBLE CAUSE	WHAT TO CHECK	REMEDY
<b>CAN'T START BREW CYCLE</b>	<ol style="list-style-type: none"> <li>1. No water.</li> <li>2. No power.</li> <li>3. ON/OFF or lower warmer switch. (Power switch on dispenser brewers.)</li> <li>4. Brew start switch.</li> <li>5. Control board harness.</li> <li>6. Solenoid valve.</li> </ol>	<ol style="list-style-type: none"> <li>1. Incoming water lines and water shutoff valve.</li> <li>2. Fuse or circuit breaker. Power cord and plug connections.</li> <li>3. Is switch turned on?</li> <li>4. Switch continuity. (Normally open).</li> <li>5. Wire leads to solenoid and switch terminals.</li> <li>6. (A) Voltage at solenoid valve terminals. Start a brew cycle and check for proper voltage. (B) If correct voltage is present at terminals, check for water at line pressure on the inlet side of solenoid valve.</li> </ol>	<ol style="list-style-type: none"> <li>1. Be sure water shutoff valve is open.</li> <li>2. Replace or reset circuit breaker as required. Unit should be plugged in securely.</li> <li>3. Switches must be on to start brew cycle. If switch does not make and break contact between terminals 1 and 2, replace switch.</li> <li>4. If brew switch does not make and break contact, replace brew start switch.</li> <li>5. Make sure these connections are tight. If so, and all else checks out OK, replace timer.</li> <li>6. (A) If voltage is not present at terminals refer to steps 2 through 5. (B) If voltage is present at terminals and water at line pressure is present on the inlet side of the solenoid, but not present on the outlet side, replace solenoid or solenoid coil.</li> </ol>
<b>NO HOT WATER</b>	<ol style="list-style-type: none"> <li>1. Tank heater.</li> <li>2. Hi-limit thermostat or main thermostat.</li> </ol>	<ol style="list-style-type: none"> <li>1. Check the voltage at the tank heater terminals. Refer to serial tag for proper voltage.</li> <li>2. Check the voltage between the white wire on the tank heater terminal and the incoming terminal (blue wire) on the hi-limit thermostat, then the outgoing terminal (black wire) on the hi-limit thermostat.</li> </ol>	<ol style="list-style-type: none"> <li>1. (A) If correct voltage is present at the tank heater terminals, and water in tank is not being heated, replace the tank heater. (B) If voltage is not present at the tank heater terminals refer, to Step 2. (C) If incorrect voltage is present at the tank heater terminals, check voltage at outlet.</li> <li>2. (A) If voltage is present on the incoming terminal of the hi-limit thermostat, but not on the outgoing terminal, replace the hi-limit thermostat. (B) Check voltage between black and white wire on the receptacle. If voltage is not present check outlet or circuit breaker. (C) If voltage is not present on the incoming terminal of the hi-limit thermostat, replace the main thermostat.</li> </ol>
<b>STEAMING OR SPITTING AROUND FUNNEL</b>	<ol style="list-style-type: none"> <li>1. Main thermostat.</li> <li>2. High altitude.</li> </ol>	<ol style="list-style-type: none"> <li>1. Thermostat Points stuck or out of calibration.</li> <li>2. Located above 5,000 feet.</li> </ol>	<ol style="list-style-type: none"> <li>1. Thermostat should be calibrated or replaced.</li> <li>2. See installation instructions.</li> </ol>
<b>DRIPPING</b>	<ol style="list-style-type: none"> <li>1. Not siphoning properly.</li> <li>2. Solenoid valve not seated properly.</li> </ol>	<ol style="list-style-type: none"> <li>1. Water should flow freely from the sprayhead.</li> <li>2. Solenoid valve assembly. (SEE FIGURE 3)</li> </ol>	<ol style="list-style-type: none"> <li>1. (A) Clean sprayhead holes. (B) Check tightness of sprayhead tube. (C) See "LIMING" page 3.</li> <li>2. Be sure spring is in place and any particles are cleaned from diaphragm. If diaphragm is worn or mutilated, replace solenoid valve.</li> </ol>
<b>WATER KEEPS RUNNING</b>	<ol style="list-style-type: none"> <li>1. Solenoid valve.</li> <li>2. Start switch.</li> <li>3. Control board/timer.</li> <li>4. Micro switch. (Located behind faucet)</li> </ol>	<ol style="list-style-type: none"> <li>1. Refer to "DRIPPING" Step 2.</li> <li>2. Remove wires from switch and check continuity.</li> <li>3. Control board is non-repairable.</li> <li>4. (A) Remove wires from switch and check continuity. (B) Switch arm or bracket binding with handle preventing shut off.</li> </ol>	<ol style="list-style-type: none"> <li>1. Refer to "DRIPPING" Step 2.</li> <li>2. If switch does not make and break continuity, replace switch.</li> <li>3. If timer will not shut off, replace board.</li> <li>4. (A) If switch does not make and break continuity replace switch. (B) Replace.</li> </ol>
<b>OVER FLOWING</b>	<ol style="list-style-type: none"> <li>1. Receiving decanter not completely empty at the start of the brew cycle.</li> <li>2. Not siphoning properly.</li> </ol>	<ol style="list-style-type: none"> <li>1. Operating instructions.</li> <li>2. Refer to "DRIPPING" Step 1.</li> </ol>	<ol style="list-style-type: none"> <li>1. Always start brew cycle with receiving decanter empty.</li> <li>2. Refer to "DRIPPING" Step 1.</li> </ol>

## TROUBLE SHOOTING GUIDE

SYMPTOM	POSSIBLE CAUSE	WHAT TO CHECK	REMEDY
<b>IRREGULAR YIELD</b>	<ol style="list-style-type: none"> <li>1. Not siphoning properly.</li> <li>2. Control board/timer.</li> <li>3. Fluctuating water pressure.</li> <li>4. Solenoid valve.</li> <li>5. Flow washer.</li> <li>6. Micro switch.</li> </ol>	<ol style="list-style-type: none"> <li>1. Refer to "DRIPPING" Step 1.</li> <li>2. Timer consistency. Time several brew cycles.</li> <li>3. Water pressure.</li> <li>4. Refer to "DRIPPING" Step 2.</li> <li>5. Possible lime build up in flow washer or flow control.</li> <li>6. Refer to "WATER KEEPS RUNNING" Step 4.</li> </ol>	<ol style="list-style-type: none"> <li>1. Refer to "DRIPPING" Step 1.</li> <li>2. If times are irregular replace board.</li> <li>3. If pressure fluctuates 10-20 PSI during operation of brew cycle, add a pressure regulator to inlet side of brewer, set to lowest pressure level registered. adjust timer to yield correct water level.</li> <li>4. Refer to "DRIPPING" Step 2.</li> <li>5. (A) Replace flow washer and clean screen. Screen is located inside solenoid. (B) Flow washer must be .250 GPM.</li> <li>6. Refer to "WATER KEEPS RUNNING" Step 4.</li> </ol>
<b>DRY COFFEE REMAINING IN BREW BASKET AFTER BREWING</b>	<ol style="list-style-type: none"> <li>1. Filters.</li> <li>2. Not siphoning properly.</li> <li>3. Improper loading of the brew basket.</li> </ol>	<ol style="list-style-type: none"> <li>1. Are correct filters being used.</li> <li>2. Refer to "DRIPPING", Step 1.</li> <li>3. Filter and coffee in brew basket.</li> </ol>	<ol style="list-style-type: none"> <li>1. Insert correct filter into brew basket.</li> <li>2. Refer to "DRIPPING" Step 1.</li> <li>3. Filter should be centered in the brew basket and coffee bed should be level.</li> </ol>
<b>WEAK COFFEE</b>	<ol style="list-style-type: none"> <li>1. Filters.</li> <li>2. Low water temperature.</li> <li>3. Not siphoning properly.</li> <li>4. Improper loading of brew basket.</li> <li>5. Missing sprayhead.</li> </ol>	<ol style="list-style-type: none"> <li>1. Are correct filters being used.</li> <li>2. Check water temperature. Refer to installation instructions.</li> <li>3. Refer to "DRIPPING" Step 1.</li> <li>4. Filter and coffee in brew basket.</li> <li>5. Check for sprayhead.</li> </ol>	<ol style="list-style-type: none"> <li>1. Insert correct filter into brew basket.</li> <li>2. Adjust thermostat control knob to obtain correct water temperature.</li> <li>3. Refer to "DRIPPING" Step 1.</li> <li>4. Filter should be centered in brew basket and coffee bed should be level.</li> <li>5. Install sprayhead.</li> </ol>
<b>SOLENOID CHATTER OR HOWLING</b>	<ol style="list-style-type: none"> <li>1. Brewer connected to hot water line.</li> <li>2. Vibration.</li> <li>3. High water pressure.</li> <li>4. Water hammer.</li> <li>5. 60 Cycle vibration.</li> </ol>	<ol style="list-style-type: none"> <li>1. Incoming water line.</li> <li>2. If brewer is on a metal stand or counter, neither the bottom pan nor copper tubing to the brewer should touch the counter.</li> <li>3. Water pressure on incoming line.</li> <li>4. Incoming plumbing.</li> <li>5. Screws on solenoid valve.</li> </ol>	<ol style="list-style-type: none"> <li>1. Should be connected to cold water line.</li> <li>2. Adjust as necessary.</li> <li>3. If water pressure is over 90 PSI install a pressure regulator and adjust to 50 PSI.</li> <li>4. This is not the fault of the brewer and can usually be corrected by rearranging some plumbing or adding an air chamber to the incoming water line.</li> <li>5. Screws should be tight. Tighten as required.</li> </ol>
<b>COLD WARMER STATION</b>	<ol style="list-style-type: none"> <li>1. Warmer - defective.</li> <li>2. Warmer On/Off switch.</li> <li>3. Bad harness.</li> </ol>	<ol style="list-style-type: none"> <li>1. Voltage at warmer terminals should be 120 V ac.</li> <li>2. If voltage is not present on warmer terminals, check continuity of the switch.</li> <li>3. Check connections between harness and switch, and between switch and warmer.</li> </ol>	<ol style="list-style-type: none"> <li>1. If voltage is present on terminals of warmer element, but warmer will not heat, replace the element.</li> <li>2. If switch does not make and break continuity (between terminals 1 and 2) when turned on and off, replace switch.</li> <li>3. All connections should be tight.</li> </ol>
<b>FAUCET DRIPPING</b>	<ol style="list-style-type: none"> <li>1. Clogged valve seat.</li> </ol>	<ol style="list-style-type: none"> <li>1. Valve seat.</li> </ol>	<ol style="list-style-type: none"> <li>1. Disassemble and clean or replace as required.</li> </ol>
<b>FAUCET FLOW SLOW</b>	<ol style="list-style-type: none"> <li>1. Entrapped air in line.</li> <li>2. Faucet clogging.</li> </ol>	<ol style="list-style-type: none"> <li>1. Tank to faucet line.</li> <li>2. Faucet.</li> </ol>	<ol style="list-style-type: none"> <li>1. Refer to "INSTALLATION INSTRUCTIONS" Step 3.</li> <li>2. Clean or rebuild faucet.</li> </ol>

## ACE SERIES BREWERS – REPLACEMENT PARTS LIST

### ELECTRICAL COMPONENTS

Part No	Description
100010	Warming plate ass'y 120 V, black
100187	Warming Element, 120 V 100 W
102581	Element main heating, 1100 W 120 V
102580	Element main heating, 1400 W 120 V
100071	Element main heating, 1750 W 120 V
102850	Element main heating, 3500 W 240 V
704227	Main thermostat
111593	Hi-limit Thermostat, manual reset
100085	Lighted rocker switch 120 V
201985	Brew switch, black, rectangular
102775	Dual lamp, brewing/ready indicating 120 V
102862	Micro switch & bracket ass'y
102841	Micro switch only
121723	Control board ass'y with bracket, (non TS models)
111725	Control board ass'y with bracket, (TS models)
100500	ON/OFF switch

### BREWBASKETS

110985	Brew basket assy, black plastic
201954	Filter pack brew basket
102800	Brew rail, LH
102799	Brew rail, RH
102370	Brew basket, S/S small
104010	Brew rail, RH, S/S basket
104011	Brew rail, LH, S/S basket

### TANK AND PLUMBING

Part No	Description
102798	Tank ass'y, 120 V 1400 W
102859	Tank ass'y, 120 V 1750 W
102746	Tank ass'y, 240 V 3500 W
104012	Tank lid ass'y
781181	Gasket, silicone tank
100024	Sprayhead, S/S 5 hole
102820	Solenoid valve assembly with fittings
102780	Solenoid valve, S-45
201158	Repair kit, solenoid valve
790019	Gasket, flow control
100290	.250 flow control washer
102770	Faucet w/red handle
102268	Seat cup for faucet
110322	PDS low/flow assembly
102783	Sprayhead tube ass'y
100025	Sprayhead gasket

### MISC.

100078	Bumper foot with screw
108067	Probe ass'y, weldment
201173	Sprayhead nut

For additional replacement parts information refer to Ace Series replacement parts manual, P/N 108054.

### PDS Flow Control Supplemental Information

The PDS flow control system is the result of many years of engineering effort to create a flow control valve that would be accurate over a wide range of water pressures as well as maintain its volume setting for many years within the harsh water environment that coffee brewing equipment must operate.

The valve has been designed to allow for adaptation to all varieties of brewers, and is available in both a low flow (0.15 GPM to 0.35 GPM) and high flow (0.56 to 1.25 GPM) model. Both models have adjustable flow rates to any setting within the specified range. The low flow models are identifiable by their red bonnet while the high flow models have a green bonnet. See item 14 in figure below.

Other features designed into the valve include an internal water strainer, a non-regulated water supply for connecting to independent faucets, an easy to adjust knob for setting the flow rate, double O-ring swivel fittings to eliminate leaks due to equipment being moved, and most importantly a porcelain sleeve and piston assembly that is self cleaning and cannot be affected by chemicals within the water supply. The system has been designed to operate over a wide range of water pressures, from 10 PSI to 70 PSI for low flow models and from 40 PSI to 110 PSI for high flow models, with an accuracy of +/- 1%.

The time setting of the brewer timer works in conjunction with the flow rate set on the PDS valve. This determines the volume of water being delivered for the brew cycle. If the valve is set at a rate of .25 GPM and the timer is set for 2 minutes, the volume delivered will be .25 x 2 or one half gallon (64 oz). Refer to table 1 for other flow rates, timer settings and volumes. Flow rate accuracy is critical as the timer setting will remain constant.



Table 1 - Timer Setting Required To Obtain Desired Volume									
Desired	Flow Rate - In Gallons Per Minute								
Volume	0.175	0.200	0.220	0.250	0.300	0.350	0.500	0.750	1.000
1 liter	91	79	71	63	53	45	32	21	16
64 oz	171	150	136	120	100	86	60	40	30
72 oz	193	169	153	135	113	96	68	45	34
2.2 liters	199	174	159	139	116	100	70	46	35
2.5 liters	226	198	180	159	132	113	79	53	40
3 gallons	1029	900	818	720	600	514	360	240	180
Brew Time Shown is in Seconds									

Table 2 - PDS Parts List					
Item	Part No	Description	Item	Part No	Description
1	110217	PDS Flow Valve Body	8d	103936	Adapter, 1/8 NPT Fem x .750 O-Ring
2	110580	Retainer, Outlet Fittings	9	110219	O-Ring, .625 ID x .750 OD
3	110218	O-Ring, .375 ID x .500 OD	10	110213	O-Ring, .562 ID x .750 OD
4a	110220	Adapter, 1/4 FL x .500 O-Ring	11	110117	Sleeve, Ceramic
4b	110108	Plug, .500 O-Ring	12	110116	Piston, Ceramic
4c	110212	Adapter, 1/8 NPT x .500 O-Ring	13a	110101	Spring, Low Flow Valve
4d	110111	Adapter, 3/8 Stem x .500 O-Ring	13b	110226	Spring, High Flow Valve
5	110223	Screw, #8 x .500 S/S Hex Head	14a	110216	Bonnet, Low Flow Valve
6	110109	Retainer, Inlet Fitting	14b	110227	Bonnet, High Flow Valve
7	110114	Filter Screen, S/S	15	110214	O-Ring, .312 ID x .500 OD
8a	110221	Adapter, 1/4 FL x .750 O-Ring	16	110222	Plug, Flow Adjustment
8b	110211	Adapter, 1/8 NPT x .750 O-Ring	17	110098	Retainer, Flow Adjustment
8c	110112	Adapter, 3/8 Stem x .750 O-Ring			

PDS Valve Diagram

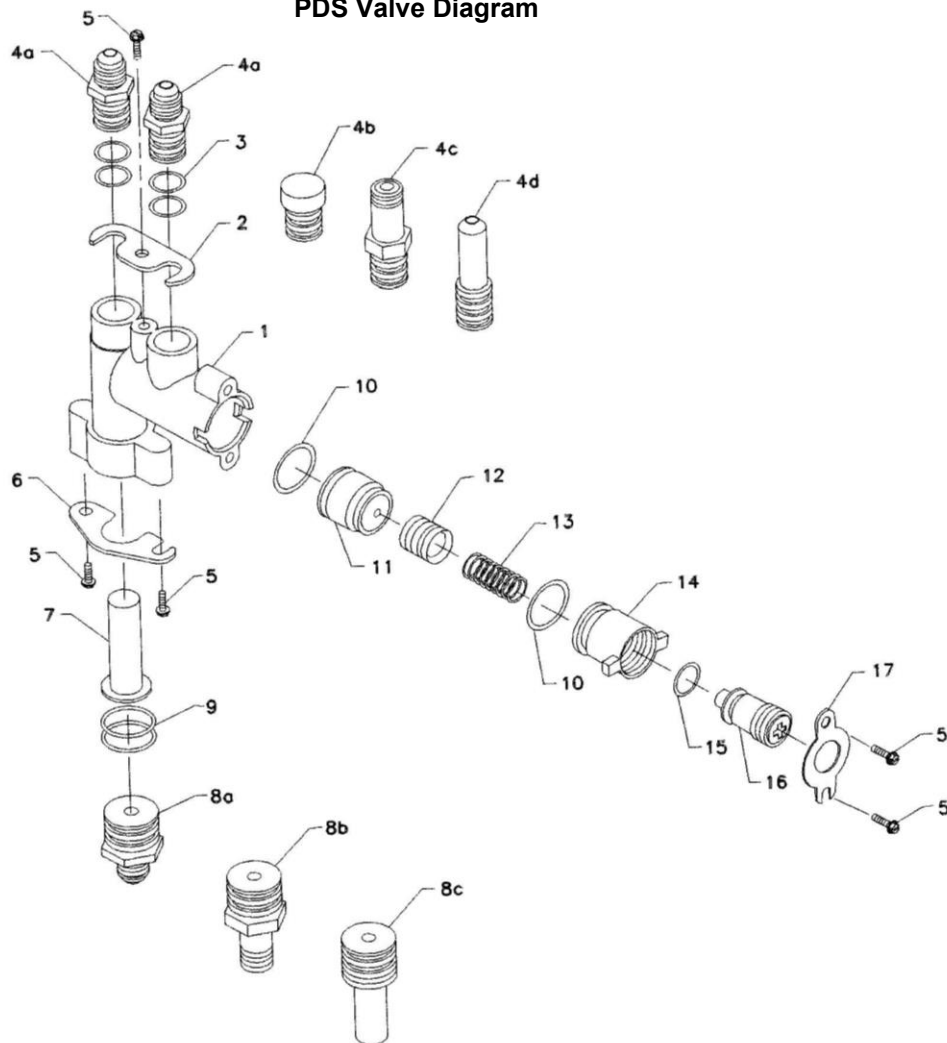

## Telescoping Brewer Supplemental Information

Telescoping Brewer Principal of Operation - Your brewer is equipped with a telescoping column to allow periodic adjustment of the brewer height. This feature allows continued use of the same piece of brewing equipment although the dispensers may change over time. The brewer has an inner and an outer column which slide up and down against each other. Three functional elements combine together to give the telescoping brewer its unique characteristics and strength. Refer to figure on next page.

- A flat “spring” lock (B), secured to the tank shelf, engages detents located internally on both sides of the wrapper and carries the bulk of the units weight.
- Retainer straps (F), secured after height adjustment, prevent the head from lifting.
- Screws (D), which secure the outer back to the column, tie the inner and outer column together providing additional strength and stability.

### Adjusting Telescoping Brewers

1. Perform the following steps in the order outlined prior to attempting brewer adjustment.
  - Disconnect Power from electrical supply.
  - Disconnect brewer from water supply.
  - Allow brewer to cool.
  - For easier adjustment, remove brewer top cover and tank lid, then siphon water from tank.
2. Remove the outer lower back (H) from the outer column (M) by removing the two screws (D) near the backs lower edge. Note these screws secure the columns together, so use caution as the head assembly will be loose once they are removed.
3. Remove the inner lower back (K) from the inner column (N). It is not necessary to remove the other two brewer back panels (G & J).
4. Locate the two brass knurled nut assemblies (E) attached to the retainer straps (F) at the front of the brewer. Loosen the assembly by turning nut counterclockwise. DO NOT REMOVE.
5. The brew head is now able to be adjusted up and down depending on its current position. Multiple techniques may be used to raise or lower the brew head so use the one that works best for you.

To RAISE the brew head:

Grasp the outer column (M) from behind with one arm while holding the base (O) in position with the other. Raise the brewer to the appropriate height for your dispenser and brewbasket combination. The brew head may also be raised by lifting against the bottom of the tank shelf (A) or by using the handles (C), located on the flat spring, while holding the brewer base in position. Ensure that the flat spring lock (B) fully engages an entire row of detents on each side of the brewer and that the rows are the same height from side to side.

To LOWER the brew head:

Grasp the outer column from behind with one arm for support while squeezing the spring lock handles (C) together. Lower the brewer to the appropriate height for your dispenser and brewbasket combination. Ensure that the flat spring lock fully engages an entire row of detents on each side of the brewer and that the rows are the same height from side to side. At the lowest position ensure that the spring lock does not set on the screws which secure the column to the base (L).

6. Slide the knurled nut assemblies (E) to a readily accessible location for future adjustments and tighten them securely.
7. Replace the inner lower back (K) on the inner column.
8. Replace the outer lower back (H) in position on column and locate the obround slot which lines up with a hole in the inner column. Secure the back to the columns with the screws previously removed. Check brewer for stability.
9. Refill tank with water and replace tank lid and brewer top cover. Reconnect brewer to water and electrical supply and follow brewer operating instructions for setup and calibration of new brew volume if required.

Note: The screws (I) holding upper inner back should not normally be removed. If they are removed they should only be replaced with screw of same length to avoid interference with internal components during adjustment.

## Telescoping Brewer Chassis Diagrams

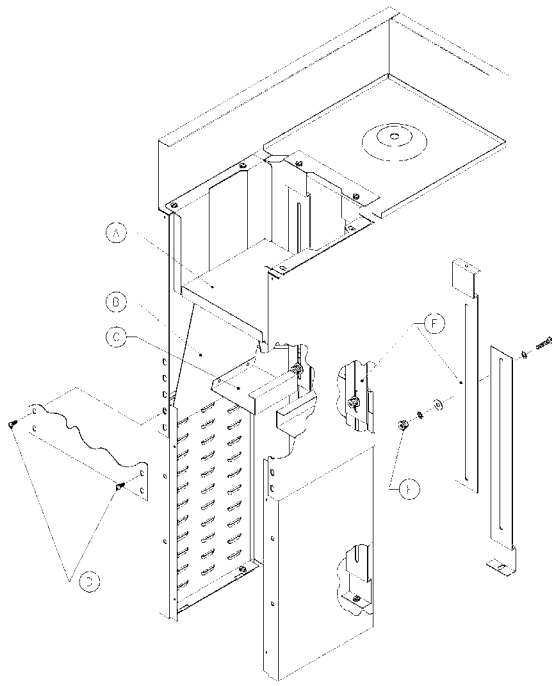

FIG 1 - BREAK AWAY VIEW

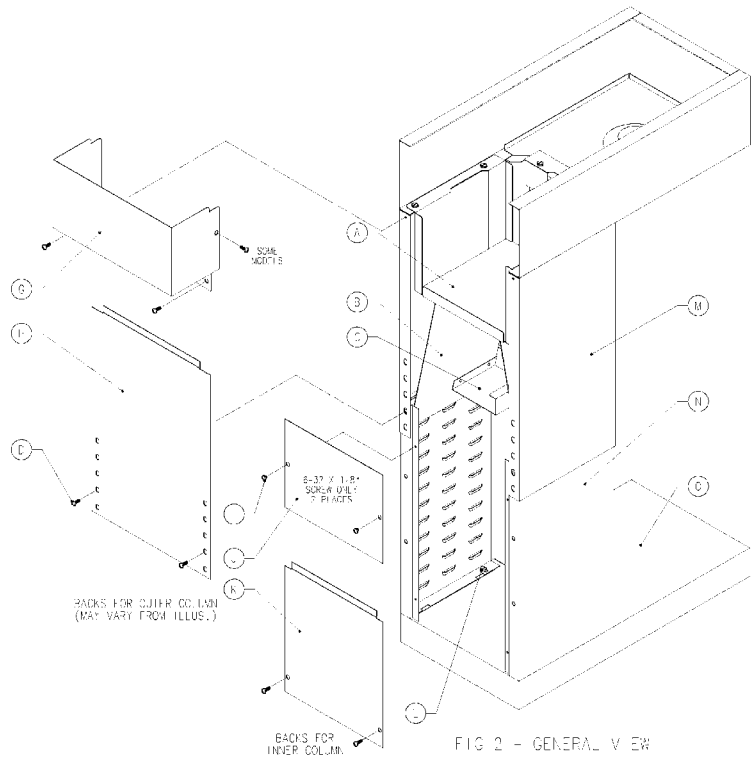
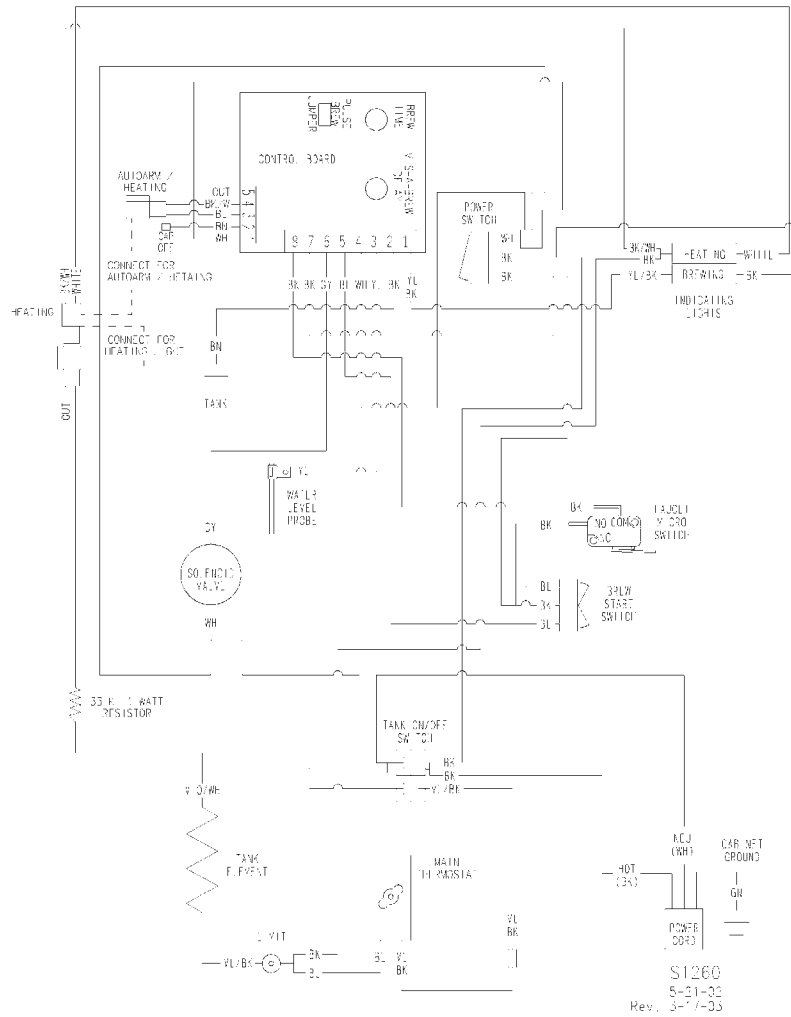

FIG 2 - GENERAL VIEW

## Telescoping Brewer 120 V Wiring Diagram



S1260  
5-21-03  
Rev. 3-7/-03

# WIRING DIAGRAMS

## 120V WARMER

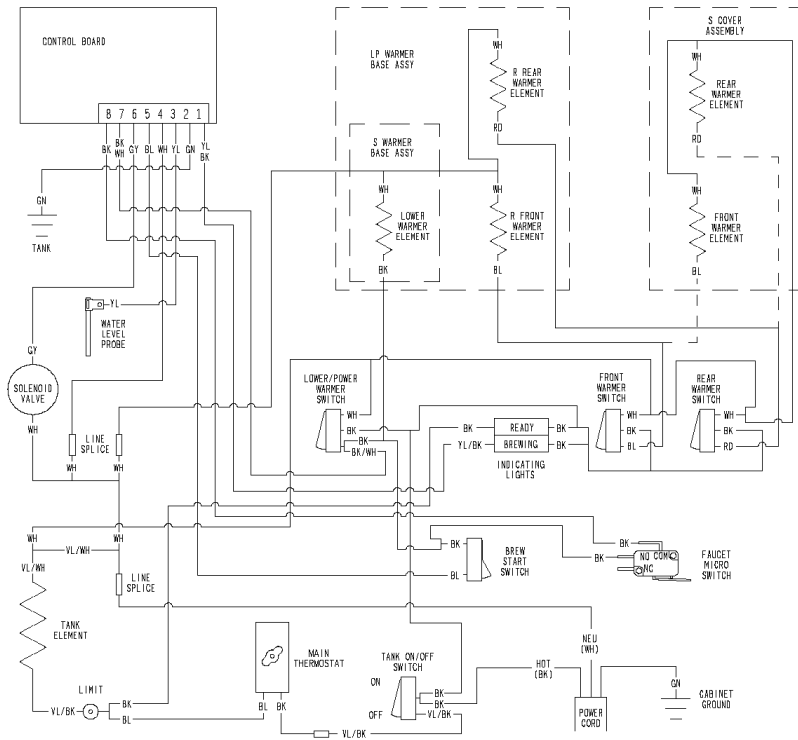

## 120V DISP.

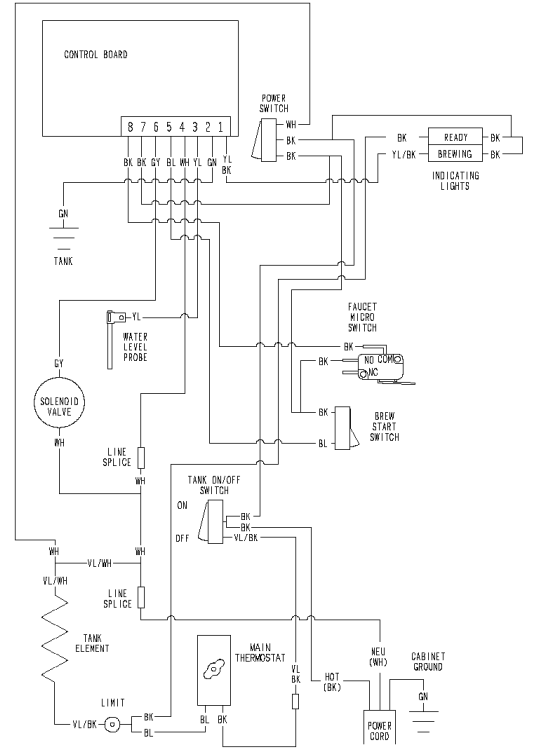

## 240V WARMER

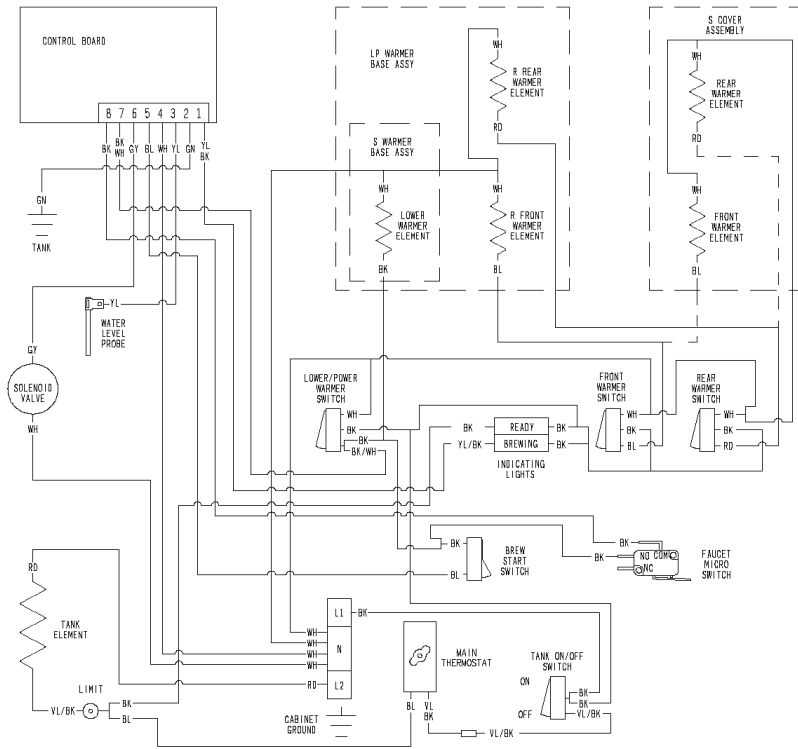

## 240V DISP.

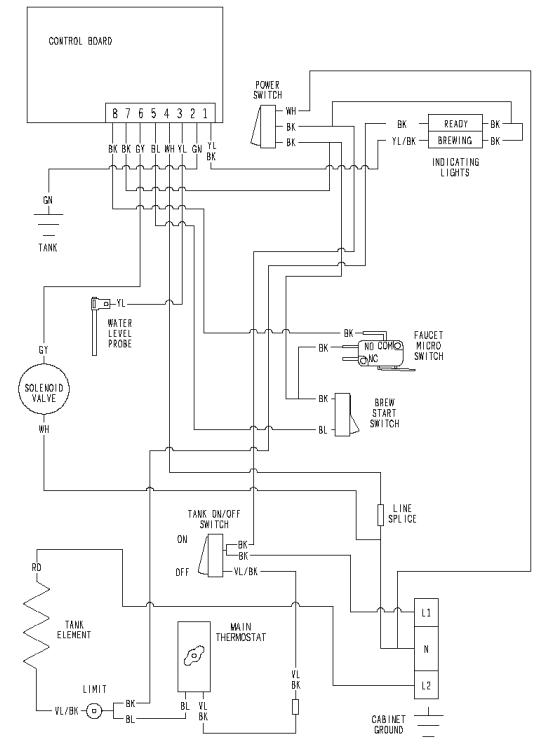

# Wiring Continued - Thermal Brewer Shown With Autoarm

240V

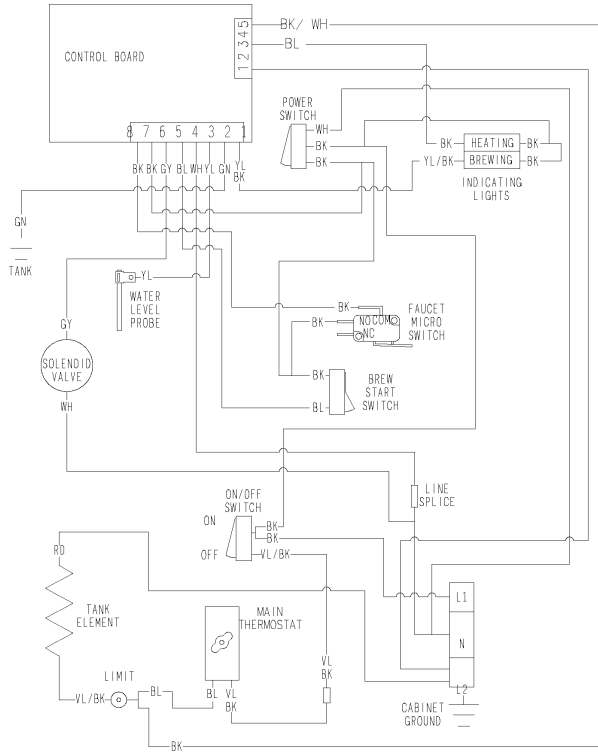

120V

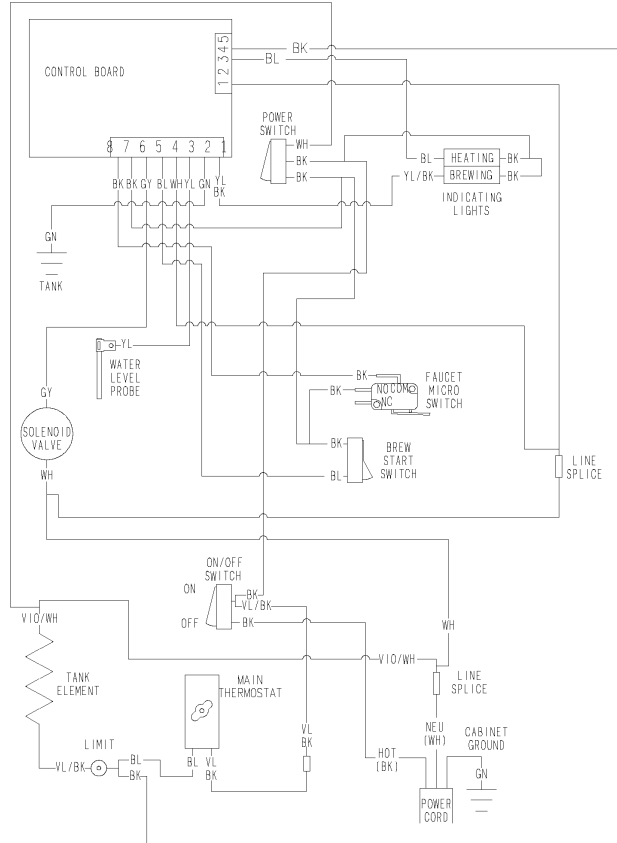

## Miscellaneous Figures

Valve Section View

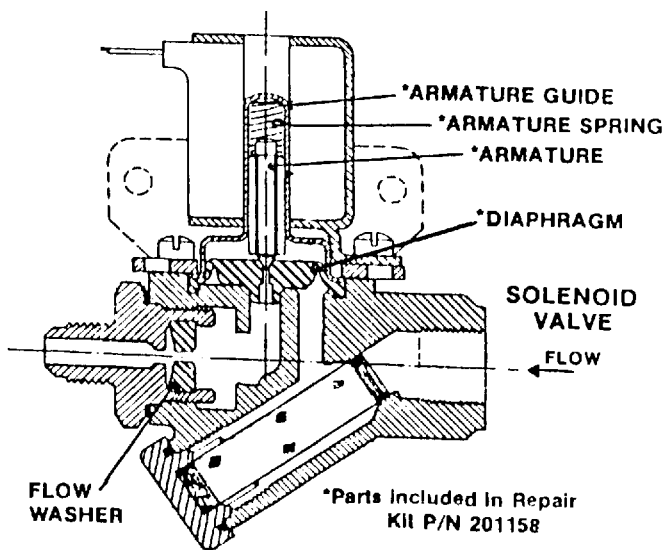

Micro Switch Section View

