



Model: CBD 1.5 Solid State Relay

SERVICE MANUAL
COMMERCIAL BARISTA SERIES

Introduction

The GXD Digital Series Brewers incorporate the latest features in brewer control technology along with the proven brewing system you have come to rely on. Although providing for enhanced functionality brewer controls remain intuitive and setup of key operating parameters couldn't be easier. Multiple brew volumes, visa-brew delay, tank temperature set point, brew mode, filter parameters and more, are all set from the front control panel using a digital display for precise control. The following pages will explain the control features and then step through the process required to program your unit.

Brew Volume – Each side of the GXD brewer has two independently programmable brew volumes denoted Brew 1 and Brew 2. Either of these brew times may be turned off or set for any volume between 30 seconds and 15 minutes for ultimate flexibility. Turning brew 1 off on the left hand side of brewer will activate the test/calibration mode.

Test / Calibration Mode – The test and calibration mode is used to display the actual tank temperature and the total number of brews using the brew 1 button. This program mode is only available when brew number 1 has been disabled. To activate the display depress the BREW 1 button. When the button is depressed the display will show the actual tank temperature which the brewer is set for. Pressing BREW 1 button again will display the number of brews for brew 2. The selected item will display until beginning a brew cycle or pressing cancel.

Hot Water Bypass – If set to on, “off” on Brew 1, this feature will activate a second dump valve, “on” for Brew 2, to allow for brewing larger volumes without a corresponding increase in brew time. This will help to preserve the beverage quality on larger brew volumes.

Visa-Brew Time – Provides for additional time to flash brew light, after the water delivery portion of brew cycle, to allow for the coffee to finish draining from the brew basket. The flashing indicator light, and the delay in the audible coffee ready signal, aid in preventing premature removal of either the brew basket or the dispenser.

Water Temperature Set Point – Allows for digitally setting the temperature of the water in the brewers tank system to any value between 170 and 205 Deg F.

Auto Arm – When enabled this feature ensures that the brewer is up to temperature prior to brewing to ensure proper extraction is obtained. If the water temperature in the tank is below the water temperature set point when the brew cycle is initiated, the water delivery portion of the brew cycle is delayed. The heating light will begin to flash indicating that the unit is in the brew mode but is not up to temperature. At the same time, the tank heater will begin heating. When the tank reaches the preset temperature, the brew cycle will resume. Auto arm may be overridden by depressing the appropriate brew button for several seconds until the brew cycle starts.

Pre-infusion mode – This mode delivers a small amount of hot water over the coffee grounds and then pauses. This allows the gasses in the coffee to escape and allows the grounds to absorb the water before continuing. After this pause the brew cycle resumes normally. Pre-infusion can yield better extraction rates than normal brewing modes. The pause time is added to the brew and visa brew time. The pre-infusion times are preset at the factory. Pre-infusion for Brew 1 and 2 may be turned on and off independently. **Note: Do not use the Pulse mode & Pre-infusion mode together.**

Pulse Brew Mode – This mode cycles the valve on and off during the brew cycle. This slows the entry of cold water into the tank and minimizes the mixing action caused by introducing a large volume of cold water into the tank at one time resulting in an increase in brew temperature. The additional turbulence and mixing created along with the increased temperature can result in higher extraction rates for the coffee. The time set for pulse brewing should exceed the time set for brew time. The time difference between the pulse brew time and the brew time is the amount of time available as off time. The difference is divided equally and distributed throughout the brew cycle to provide a pulse after every 20 seconds of brewing. Pulse brew mode for Brew 1 and 2 may be turned on and off independently. **Note: Do not use the Pulse mode & Pre-infusion mode together.**

Introduction (Continued)

Audible Alert Mode – Provides an audible signal when coffee has finished brewing notifying everybody that fresh coffee is available. May be turned on or off and set for 1-9 beeps.

Coffee Freshness Monitor – Monitors the elapsed time since the brew cycle to assure the coffee is fresh. Freshness time may be set for 10 minutes to 2 hours. The last 10 minutes of the freshness time are counted down on the display and when the preset time is reached a beep is sounded and the coffee monitor light begins to flash.

Filtering Flow Rate – This is the flow rate of incoming water and is used to calculate the volume of water that has been filtered. The flow rates may be turned off or set for .25, .50, .75 or 1.00 gallon per minute flow rates. Note: A filter with a minimum flow rate of 1 GPM minimum is recommended. The left hand board provides the monitoring function for both sides of the brewer.

Filter Capacity – The filtering capacity in gallons of the filter installed (optional) on the brewer may be selected here. Capacity may be turned off or set for one of the following available values; 0, 500, 1500, 2000 or 2500 gallons.

Number of Brews – The number of brew cycles started may be tracked with this feature. The accumulated number of cycles may be reset. Using the brew buttons, first display “Clr” when in the program mode, then depress cancel.

Power Mode - allows you to automatically save energy when the brewer is not in use for a length of time specified under power shutdown time. Available modes are normal, power save (standby) and power down. The modes are described below.

- Normal - In this mode the tank temperature will be maintained at the preset temperature at all times.
- Power Save (Standby) - In this mode the tank temperature will be maintained at approximately 170 degrees when the set time has been reached. Brew 1 light will flash about once every 10 seconds to indicate unit is in power save mode.
- Power Down - In this mode the tank heater element will be disabled when the set time has been reached.

Brew 2 light will flash about once every 10 seconds to indicate unit is in power down mode. By depressing the brew start switch, the timer is reinitialized and the set time frame starts over. In standby and power down modes the auto arm feature, if enabled, will bring the tank up to the preset temperature before brewing when the brew switch is depressed.

Power Shutdown Time – This feature is used to set a specified length of time ranging from 30 to 240 minutes before the standby or power down modes will take effect.

Please Note:

The digital control boards are the same board for both the left-hand and right-hand side of the brewer. The board on the left-hand side however, requires a jumper across the center pins of the connector on the edge of the board. This allows the software to recognize it as the master board for purposes of tank heater control, etc.

SEQUENCE OF PROGRAMMING STEPS FOR THE DIGITAL CONTROLLER

TURN BY-PASS VALVE GREEN ADJUSTMENT SCREW CLOCKWISE TO CLOSE. TURN BACK OUT 4 FULL TURNS. THIS SHOULD GET 20 OUNCES OF BY-PASS. INCREASE OR DECREASE ACCORDINGLY.

- Depress and hold Cancel and brew 1 button until display lights up (Approx. 10 seconds).
- You are now in the Program Mode. Functions to be programmed appear in the order in which they are shown in the following table. The master control board (Left side) has more options to program than does the slave board (Right side).
- Use the Cancel button to cycle through the functions to find the one you wish to change.
- Use the BREW 1 button to lower the displayed value and the BREW 2 button to raise the value. Press Cancel to store the changed value and advance to next function.
- If the Brewer detects no activity for approx. 60 seconds it will exit the Program Mode, except as noted below.

L	CODE	R	FUNCTION TO SET	SET VALUES AVAILABLE	LEFT SIDE	RIGHT SIDE
Y	1A	Y	Brew 1 time	OFF, 30 seconds – 15 minutes	128/1-Gal. (2:54+/-)	128/1-Gal. (2:54+/-)
Y	1b	Y	Brew 2 time	OFF, 30 seconds – 15 minutes*	192oz/1.5 Gal (4:05+/-)	192oz/1.5 Gal (4:05+/-)
Y	2A	Y	Brew 1 Double dump feature	ON or OFF	OFF	OFF
Y	2b	Y	Brew 2 Double dump feature	ON or OFF	ON (20oz)	ON (20oz)
Y	3	Y	Visa-brew time	OFF, 30 seconds – 2 ½ minutes	1:30	1:30
Y	4	Y	Water Temperature 1	170 °F – 205 °F	202	202
Y	5	Y	Auto Arm	ON or OFF	ON	ON
Y	6A	Y	Pre-infusion 1 mode	ON or OFF	OFF	OFF
Y	6b	Y	Pre-infusion 2 mode	ON or OFF	OFF	OFF
Y	7	Y	Pulse brew mode	ON or OFF	ON	ON
Y	7A	Y	Pulse brew 1 time 2	OFF, 30 seconds – 15 minutes	6:00	6:00
Y	7b	Y	Pulse brew 2 time 3	OFF, 30 seconds – 15 minutes	8:00	8:00
Y	8A	Y	Audible alert mode	ON or OFF	ON	ON
Y	8b	Y	Audible alert no. of beeps	OFF, 1 – 9, On	4	4
Y	9	Y	Coffee freshness monitor	10 minutes – 2 hours	2 HRS	2 HRS
Y	10A	Y	Filtering flow rate	OFF, 0.25 – 1.00 gal. / min	OFF	OFF
Y	10b	Y	Filter capacity 4	OFF, 0.50 – 2.50 gal. X 100	OFF	OFF
Y	11	Y	Number of Brews	ON or OFF, Clr	N/A	N/A
Y	13A		Power mode	Normal, Power Save, Power Down	NORMAL	NORMAL
Y	13b		Power shutdown time 5	30 minutes – 4 hours	N/A	N/A
Y	End	Y	None 6	N/A	N/A	N/A

* A decimal after the last digit will indicate 10. Therefore if 4.00 is shown this is 14 minutes.

- 1 Brewer will remain in this sequence indefinitely until CANCEL button is pressed. Heating icon will track heater operation.
- 2 Hidden if pulse brew mode is OFF or brew 1 time is OFF.
- 3 Hidden if pulse brew mode is OFF or brew 2 time is OFF.
- 4 Hidden if filter flow rate is OFF.
- 5 Hidden when power save mode is normal..
- 6 Program mode will time out in 15 seconds at end of programming sequence.

ERROR MESSAGES

The following table explains the error messages which may be encountered on the brewer. The error messages may be cleared by going into the program mode, using the brew buttons to display “Clr” and then pressing the cancel button.

ERROR MESSAGE	DESCRIPTION	CAUSE
Er1	Fill run error	The fill solenoid has either run for more than six minutes on the initial tank fill or 3 minutes in normal operation.
Er2	Heater run error	The tank heater has run for more than 30 consecutive minutes.
Er3	Shorted probe	Short in the thermistor circuit.
Er4	Open probe	Break in the thermistor circuit.
Ful	Filter limit reached	The selected filtering capacity of the filter has been reached

Introduction (Continued)

Error Messages

The following table explains the error messages, which may be encountered, on the brewer. Going into the program mode, using the brew button to display “Cir” and then pressing the cancel button will clear the error messages.

Error Message	Description	Cause
Er1	Fill run error	The fill solenoid has either run for more than six (6) minutes on the initial tank fill or Three (3) minutes in normal operation.
Er2	Heater run error	The tank heater has run for more than 30 consecutive minutes.
Er3	Shorted probe	Short in the thermistor circuit.
Er4	Open probe	Break in the thermistor circuit.
Ful	Filter limit reached	The selected filtering capacity of the filter has been reached.

Wiring Diagram [Dual]

WIRING DIAGRAM CBD
SOLID STATE RELAY

#S1327
2/4/16

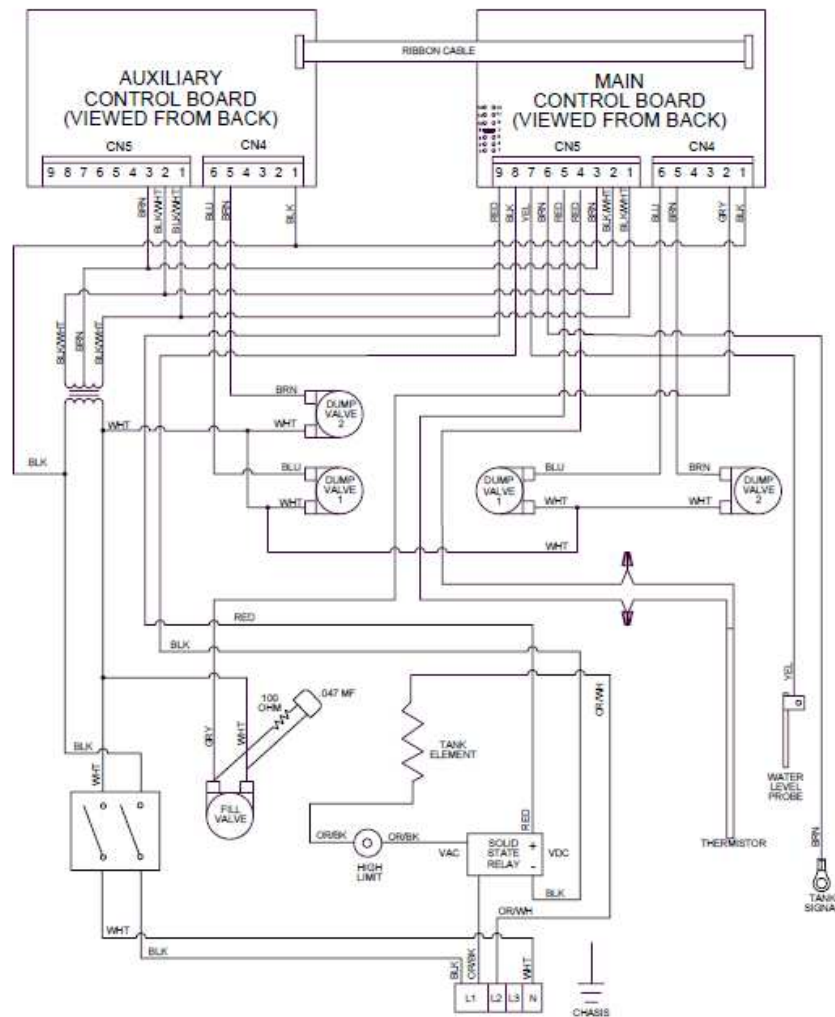

Installation Instructions

Note: Cost of installation and any subsequent fine-tuning is the responsibility of the buyer.

Warning: Read follow installation instructions before plugging in machine to an electrical outlet.

1. Remove the machine from shipping carton. It is strongly recommended to perform a visual inspection of the machine inside out checking for loose connections on either control board or for damage to outlet valve that might have been caused by mishandling during shipment. Please keep carton and packing in case the machine needs to be re-shipped.
2. Plumb in the brewer. **Caution:** Power to the machine must be off before proceeding with installation.
 - Flush water lines before installing machine. Machine should be connected to cold water line for best operation. Check incoming water pressure with pressure gauge.
 - Water pressure should be at 20 lbs. For less than a 25 foot run, use 1/4" OD copper tubing and connect to a 1/2" or larger water line. For more than a 25 foot run, use 3/8" OD copper tubing from a 1/2" or larger water line. Use an adaptor fitting for the connection to the machine.
 - If the water pressure is 50 lbs or greater, it is strongly recommended installing water regulator and set the water pressure below 50 lbs. This will prevent erratic brew levels.
 - Connect the incoming water line to the incoming main fitting [3/8 NPT x 1/4 F male] on the back of the machine.
 - Provide individual water line(s) to each machine when there are multiple machines in use.

Note: A shut off valve should be installed on the incoming water line in a convenient location.

3. Place empty server under brew basket.
4. Plug in to proper voltage circuit and turn the power on.
5. Water will automatically begin to fill the tank.

Recommended Terminal Block lug torque specifications

P/N 701972 – 35 In. lbs.

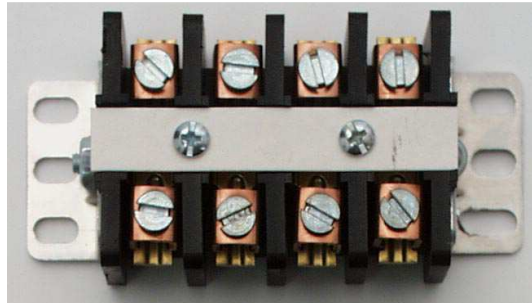

WARRANTY

Applies to all equipment manufactured after 2/1/2017. This warranty supersedes all other previous warranties that are currently in manuals.

Newco warrants equipment manufactured by it for 1 year parts and labor. Accessories and Dispensers 1 Year parts only. Electronic Circuit and Control Boards- 3 year on parts, 1 year labor. Equipment manufactured by others and distributed by Newco- please see original equipment manufacturers warranty, Newco will follow.

These warranty periods run from the date of sale Newco warrants that the equipment manufactured by it will be commercially free of defects in material and workmanship existing at the time of manufacture and appearing within the applicable warranty period. This warranty does not apply to any equipment, component or part that was not manufactured by Newco or that, in Newco's judgment, has been affected by misuse, neglect, alteration, improper installation or operation, relocation or reinstallation, improper maintenance or repair, incorrect voltage applied to the unit at any time, damage or casualty. This warranty does not apply to any equipment failures related to poor water quality, excessive lime and chlorine and non-periodic cleaning and descaling. Warranty is null and void if muriatic or any other form of hydrochloric acid is used for cleaning or deliming. In addition, this warranty does not apply to replacement of items subject to normal use including but not limited to user replaceable parts such as faucet seat cups, sight gauge tubes, washers, O-rings, tubing, seals and gaskets.

This warranty is conditioned on the Buyer 1) giving Newco prompt notice of any claim to be made under this warranty by telephone at (800) 556-3926 or by writing to **3650 New Town Blvd, Saint Charles, MO 63301**; 2) if requested by Newco, shipping the defective equipment prepaid to an authorized Newco service location; and 3) receiving prior authorization from Newco that the defective equipment is under warranty.

THE FOREGOING WARRANTY IS EXCLUSIVE AND IS IN LIEU OF ANY OTHER WARRANTY, WRITTEN OR ORAL, EXPRESS OR IMPLIED, INCLUDING, BUT NOT LIMITED TO, ANY IMPLIED WARRANTY OF EITHER MERCHANTABILITY OR FITNESS FOR A PARTICULAR PURPOSE. The agents, dealers or employees of Newco are not authorized to make modifications to this warranty or to make additional warranties that are binding on Newco. Accordingly, statements by such individuals, whether oral or written, do not constitute warranties and should not be relied upon.

If Newco determines in its sole discretion that the equipment does not conform to the warranty, Newco, at its exclusive option while the equipment is under warranty, shall either 1) provide at no charge replacement parts and/or labor (during the applicable parts and labor warranty periods specified above) to repair the defective components, provided that this repair is done by a Newco Authorized Service Representative; or 2) shall replace the equipment or refund the purchase price for the equipment.

THE BUYER'S REMEDY AGAINST NEWCO FOR THE BREACH OF ANY OBLIGATION ARISING OUT OF THE SALE OF THIS EQUIPMENT, WHETHER DERIVED FROM WARRANTY OR OTHERWISE, SHALL BE LIMITED, AT NEWCO'S SOLE OPTION AS SPECIFIED HEREIN, TO REPAIR, REPLACEMENT OR REFUND.

In no event shall Newco be liable for any other damage or loss, including, but not limited to, lost profits, lost sales, loss of use of equipment, claims of Buyer's customers, cost of capital, cost of down time, cost of substitute equipment, facilities or services, or any other special, incidental or consequential damages.