

NEWCO ENTERPRISES

INSTALLATION, OPERATION, AND SERVICE MANUAL FOR GK SERIES BREWERS

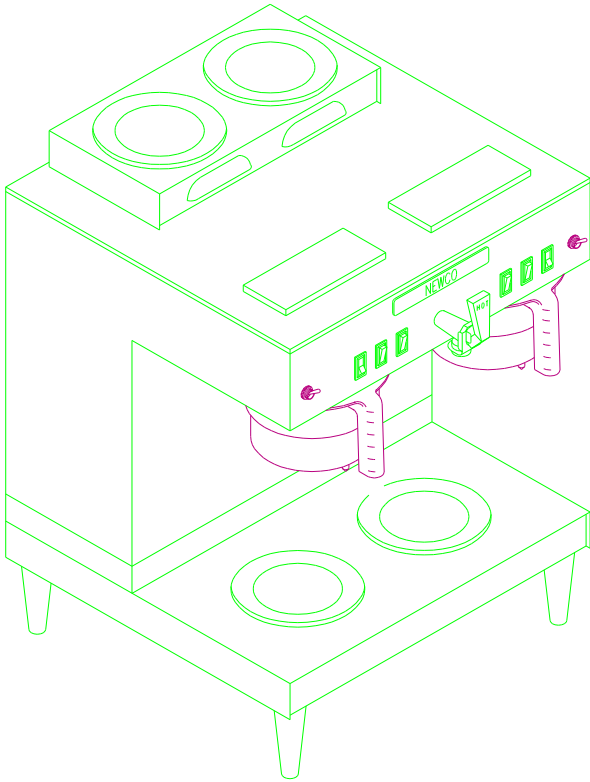

GKDF-4

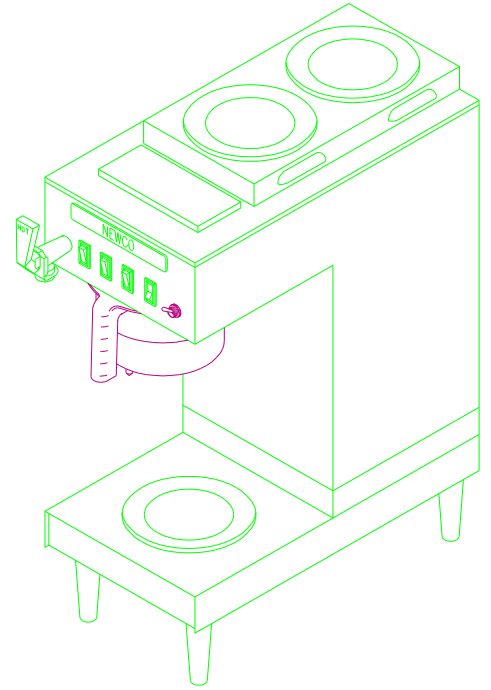

GKF-3

Model	Warmers	Width	Length	Height	Weight	Watts	Amps
GKF-1	1	9-1/2"	19"	23-1/2"	35 lbs.	1820	15.2
GKF-2	2	9-1/2"	19"	25-1/2"	37 lbs.	1920	16
GKF-3	3	9-1/2"	19"	25-1/2"	39 lbs.	2020	16.8
GKDF-2	2	19"	19"	23-1/2"	62 lbs.	5240	21.8
GKDF-4	4	19"	19"	25-1/2"	64 lbs.	5440	22.7
GKDF-6	6	19"	19"	25-1/2"	66 lbs.	5640	23.5

NOTE: Pour over models also available.

WARRANTY

Applies to all equipment manufactured after 2/1/2017. This warranty supersedes all other previous warranties that are currently in manuals.

Newco warrants equipment manufactured by it for 1 year parts and labor.

Accessories and Dispensers 1 Year parts only.

Electronic Circuit and Control Boards- 3 years parts, 1 year labor.

Equipment manufactured by others and distributed by Newco- please see original equipment manufacturers warranty, Newco will follow.

These warranty periods run from the date of sale Newco warrants that the equipment manufactured by it will be commercially free of defects in material and workmanship existing at the time of manufacture and appearing within the applicable warranty period. This warranty does not apply to any equipment, component or part that was not manufactured by Newco or that, in Newco's judgment, has been affected by misuse, neglect, alteration, improper installation or operation, relocation or reinstallation, improper maintenance or repair, incorrect voltage applied to the unit at any time, damage or casualty. This warranty does not apply to any equipment failures related to poor water quality, excessive lime and chlorine and non periodic cleaning and descaling. Warranty is null and void if muriatic or any other form of hydrochloric acid is used for cleaning or deliming. In addition, this warranty does not apply to replacement of items subject to normal use including but not limited to user replaceable parts such as faucet seat cups, sight gauge tubes, washers, o-rings, tubing, seals and gaskets.

This warranty is conditioned on the Buyer 1) giving Newco prompt notice of any claim to be made under this warranty by telephone at (800) 556-3926 or by writing to 3650 New Town Blvd, Saint Charles, MO 63301; 2) if requested by Newco, shipping the defective equipment prepaid to an authorized Newco service location; and 3) receiving prior authorization from Newco that the defective equipment is under warranty.

THE FOREGOING WARRANTY IS EXCLUSIVE AND IS IN LIEU OF ANY OTHER WARRANTY, WRITTEN OR ORAL, EXPRESS OR IMPLIED, INCLUDING, BUT NOT LIMITED TO, ANY IMPLIED WARRANTY OF EITHER MERCHANTABILITY OR FITNESS FOR A PARTICULAR PURPOSE. The agents, dealers or employees of Newco are not authorized to make modifications to this warranty or to make additional warranties that are binding on Newco. Accordingly, statements by such individuals, whether oral or written, do not constitute warranties and should not be relied upon.

If Newco determines in its sole discretion that the equipment does not conform to the warranty, Newco, at its exclusive option while the equipment is under warranty, shall either 1) provide at no charge replacement parts and/or labor (during the applicable parts and labor warranty periods specified above) to repair the defective components, provided that this repair is done by a Newco Authorized Service Representative; or 2) shall replace the equipment or refund the purchase price for the equipment.

THE BUYER'S REMEDY AGAINST NEWCO FOR THE BREACH OF ANY OBLIGATION ARISING OUT OF THE SALE OF THIS EQUIPMENT, WHETHER DERIVED FROM WARRANTY OR OTHERWISE, SHALL BE LIMITED, AT NEWCO'S SOLE OPTION AS SPECIFIED HEREIN, TO REPAIR, REPLACEMENT OR REFUND.

In no event shall Newco be liable for any other damage or loss, including, but not limited to, lost profits, lost sales, loss of use of equipment, claims of Buyer's customers, cost of capital, cost of down time, cost of substitute equipment, facilities or services, or any other special, incidental or consequential damages.

PLUMBER'S INSTALLATION INSTRUCTIONS (AUTOMATIC BREWERS)

CAUTION: Power to brewer must be OFF before proceeding with plumbing installation.

- 1) Attach flow/strainer assembly to back of brewer. Strainer inlet will point down.
- 2) Flush water line before installing brewer. Brewer should be connected to COLD WATER LINE for best operation.
- 3) Water pressure should be at least 20 lbs. For less than a 25 ft run, use 1/4" copper tubing and connect to 1/2" or larger water line. For longer runs, use 3/8" copper tubing & connect to 1/2" or larger water line and provide an adapter fitting for connection to the brewer.
- 4) If installed with saddle valve, the valve should have a minimum of 1/8" port hole for up to 25 ft run, and 5/16" port hole for over 25 ft runs.
- 5) Connect incoming water line to the strainer on the back of the brewer. Manufacturer recommends connecting to copper tubing.

INSTALLATION INSTRUCTIONS

FILL BREWER TANK WITH WATER BEFORE CONNECTING TO POWER SUPPLY !

WARNING: - Read and follow installation instructions before plugging or wiring in machine to electrical circuit. Warranty will be void if machine is connected to any voltage other than that specified on the name plate.

- 1) Place the decanter under brew basket, raise top evaporation cover and pour three decanters of water through the top pour-in screen. Water should come through the brew basket as the third decanter of water drains out of the pour in basin. If brewer does not have a pour in opening remove top cover and pour water directly into receiving pan.
- 2) For Automatic Models: Adjust timer to deliver desired amount of water (Timer is located behind front access panel). Set volume selection switch to the "1 POT" setting. To brew into a regular 60 oz. decanter, little adjustment should be needed. Turn timer dial clockwise to increase volume of water, and counter clockwise to decrease volume. The "2 POT" setting will yield twice the volume of water as the "1 POT" setting.
- 3) 120 V brewers are shipped with thermostat turned on. 240 V brewers are not and should be set after filling the tank. Plug or wire in machine to appropriate voltage circuit as noted on the brewers serial tag. Serial tag is located on rear of brewer.
- 4) Allow 10 to 15 minutes for water in tank to heat to brewing temperature. (Additional water may drip from brew basket due to initial expansion of water in the tank). This will not occur thereafter.
- 5) After water has reached brewing temperature (thermostat will click off and heating noise will stop.) turn lower warmer switch to the ON position. To remove expanded water from tank, run one cycle by pouring one decanter of water through pour-in screen (pour over models) or by depressing brew start switch (automatic models). (Brew cycle may be canceled by turning the rocker switch back to the OFF position.)
- 6) Run one cycle to check for the proper temperature setting with an accurate thermometer. Take the temperature of this water at a point below the brew basket opening, at the start of the brew cycle and when the decanter is half full. Recommended temperature of the water is approximately 195 F.
- 7) In higher altitude locations (5000 feet above sea level) the thermostat may have to be adjusted lower to prevent boiling.
- 8) **CAUTION:** On faucet models the water faucet will dispense hot water when the handle is depressed. The faucet system is independent of the brewing system and can be operated during brew cycle. Once brewer is pressurized, operate faucet until water flows smoothly.

COFFEE PREPARATION PROCEDURES

- 1) Place filter into brew basket. Set the volume selector switch to the desired brew volume.
- 2) Put the proper amount of coffee into the filter.
- 3) Slide the brew basket into holder.
- 4) Place empty decanter on warmer located directly under the brew basket and turn corresponding warmer switch to ON position.
- 5) Pour decanter of water through pour-in screen into pour in basin (pour over models) or depress brew start switch (automatic models).
- 6) Hot water will be delivered through the sprayhead. This distributes the hot water evenly over the coffee bed within the brew basket. The coffee brew will drain from the brew basket into the decanter below.
- 7) The resultant coffee brew should be crystal clear and have the desired properties attainable through excellent extraction.
- 8) **TURN OFF WARMER WHEN NOT IN USE.** Red light indicates warmer is on.
- 9) To clean brew basket simply remove from brew rails and dump filter into waste basket. The brewing process, as described above, can now be started again.

TROUBLE SHOOTING GUIDE

SYMPTOM	POSSIBLE CAUSE	WHAT TO CHECK	REMEDY
NO HOT WATER	<ol style="list-style-type: none"> 1. Tank heater. 2. Hi-limit thermostat or main thermostat. 	<ol style="list-style-type: none"> 1. Check the voltage at the tank heater terminals. Proper voltage is designated on the serial tag located on the rear of the brewer. 2. Check the voltage between the white wire on the tank and the incoming terminal (blue wire) on the hi-limit thermostat, then the outgoing terminal (black wire) on the hi-limit thermostat. 	<ol style="list-style-type: none"> 1. (A) If correct voltage is present at the tank heater terminals and water in tank is not being heated, replace the tank heater. (B) If voltage is not present at the tank heater terminals refer, to step 2. (C) If incorrect voltage is present at the tank heater terminals, check voltage at outlet. 2. (A) If voltage is present on the incoming terminal of the hi-limit thermostat, but not on the outgoing terminal, replace the hi-limit thermostat. (B) Check voltage between black and white wire on the receptacle. If voltage is not present check outlet or circuit breaker. (C) If voltage is not present on the incoming terminal of the hi-limit thermostat, replace the main thermostat.
DRIPPING	<ol style="list-style-type: none"> 1. Not siphoning properly. 2. Automatic Models: Solenoid valve not seating properly. 3. Faucet Models: Faucet coil is leaking. 	<ol style="list-style-type: none"> 1. Water should flow freely from the sprayhead. 2. Solenoid valve assembly. 3. Hot water coil. 	<ol style="list-style-type: none"> 1. (A) Clean sprayhead holes. (B) Check tightness of sprayhead tube. (C) See "LIMING" , Page 6. 2. Be sure spring is in place and any particles are cleaned from valve seat. If valve seat is worn or mutilated, replace solenoid valve. 3. Tighten fittings or replace coil.
STEAMING OR SPITTING AROUND FUNNEL	<ol style="list-style-type: none"> 1. Main thermostat. 2. High altitude. 	<ol style="list-style-type: none"> 1. Thermostat points stuck or out of calibration. 2. Located above 5,000 feet. 	<ol style="list-style-type: none"> 1. (A) Adjust thermostat. (B) Thermostat should be calibrated or replaced. 2. See "INSTALLATION INSTRUCTIONS", Page 2..
WEAK COFFEE / DRY COFFEE REMAINING IN BREW BASKET AFTER BREWING	<ol style="list-style-type: none"> 1. Filters. 2. Not siphoning properly. 3. Improper loading of the brew basket. 	<ol style="list-style-type: none"> 1. Are correct filters being used. 2. Refer to "DRIPPING", Step 1. 3. Filter and coffee in brew basket. 	<ol style="list-style-type: none"> 1. Insert correct filter. 2. Refer to "DRIPPING", Step 1. 3. Filter should be centered in the brew basket and coffee bed should be level.
CONDENSATION ON INSIDE OF CABINET	<ol style="list-style-type: none"> 1. Tank lid gasket. 2. Sprayhead tube ass'y. 3. Thermostat grommet. 4. Receiving pan nut. 5. Main thermostat set above 210 degrees. 	<ol style="list-style-type: none"> 1. Nicks or cuts in the gasket. 2. Tightness of ass'y to lid. 3. Tight fit. Nicks or cuts. 4. Receiving pan nut loose. 5. Check thermostat calibration. 	<ol style="list-style-type: none"> 1. Replace gasket. 2. Tighten sprayhead tube ass'y to tank lid. 3. Adjust or replace grommet. 4. Tighten nut. 5. Calibrate or replace thermostat.
COLD WARMER STATION	<ol style="list-style-type: none"> 1. Warmer - defective. 2. Warmer ON/OFF Switch. 3. Bad harness. 	<ol style="list-style-type: none"> 1. Voltage at warmer terminals should be 120 volts AC. 2. If voltage is not present on warmer terminals, check continuity of switch. 3. Check connections between harness and switch, and between switch and warmer. 	<ol style="list-style-type: none"> 1. If voltage is present on terminals, but warmer will not heat, replace warmer. 2. If switch does not make and break continuity when turned off, replace switch. 3. All connections should be tight.

TROUBLE SHOOTING GUIDE

SYMPTOM	POSSIBLE CAUSE	WHAT TO CHECK	REMEDY
IRREGULAR YIELD	<ol style="list-style-type: none"> 1. Not siphoning properly. Steps 2 thru 8 refer to Automatic Models 2. Timer. 3. Fluctuating water pressure. 4. Solenoid valve. 5. Flow washer. 6. Flow control screen. 7. Faucet coil is leaking. 8. Strainer. 	<ol style="list-style-type: none"> 1. Refer to "DRIPPING", Step 1. 2. Timer consistency. Time several brew cycles. 3. Water pressure. 4. Refer to "DRIPPING", Step 2. 5. Possible lime build up in flow control. 6. Screen built into flow control. 7. Refer to "DRIPPING", Step 3. 8. Water pressure at output. 	<ol style="list-style-type: none"> 1. Refer to "DRIPPING", Step 1. 2. If times are irregular, replace timer. 3. If pressure fluctuates 10-20 PSI during operation of brew cycle, add a pressure regulator to inlet side of brewer, set to lowest pressure level registered. Adjust timer to yield correct water level. 4. Refer to "DRIPPING", Step 2. 5. Replace flow washer and clean lime from flow control. 6. Replace or clean screen. Clean lime from flow control. 7. Refer to "DRIPPING", Step 3. 8. If pressure is low, clean or replace strainer.
WATER KEEPS RUNNING (AUTOMATIC MODELS)	<ol style="list-style-type: none"> 1. Solenoid valve. 2. Start switch. 3. Timer 	<ol style="list-style-type: none"> 1. Refer to "DRIPPING", Step 1. 2. Remove wires from switch and check continuity. 3. Solid state timers are not repairable. If timer will not shut off, replace timer. 	<ol style="list-style-type: none"> 1. Refer to "DRIPPING", Step 1. 2. If start switch does not make and break contact, switch should be replaced. 3. Replace timer.
CAN'T START BREW CYCLE (AUTOMATIC MODELS)	<ol style="list-style-type: none"> 1. No water. 2. No power. 3. ON/OFF switch. 4. Brew start switch. 5. Timer or timer harness. 6. Solenoid valve. 	<ol style="list-style-type: none"> 1. Incoming water lines & water shut off valve. 2. Fuse or circuit breaker. Power cord and plug connections. 3. Switch continuity. (Normally open.) 4. Switch continuity. (Normally closed.) 5. Wire leads to solenoid and black 3-pin connector. 6. (A) Voltage at solenoid valve terminals. Start a brew cycle and check for 120 volts AC. (B) If voltage is present at terminals, check for water at line pressure on the inlet side of solenoid valve. 	<ol style="list-style-type: none"> 1. Be sure water shut off is open. 2. Replace or reset circuit protector 3. If ON/OFF switch does not make and break contact, replace ON/OFF switch. 4. If brew start switch does not make and break contact, replace brew start switch. 5. Make sure these connections are tight. If so, and all else checks out OK, replace timer. 6. (A) If voltage is not present at terminals, refer to steps 2 through 5. (B) If voltage is present at terminals and water at line pressure is present on the inlet side of the solenoid, but not present on the outgoing side, replace solenoid.
SOLENOID CHATTER OR HOWLING (AUTOMATIC MODELS)	<ol style="list-style-type: none"> 1. Brewer connected to hot water line. 2. Vibration. 3. High water pressure. 4. Water hammer. 5. 60 cycle vibration. 	<ol style="list-style-type: none"> 1. Incoming water line. 2. If brewer is on a metal stand or counter, neither the bottom pan nor copper tubing to the brewer should touch the counter. 3. Water pressure on incoming line. 4. Incoming plumbing. 5. Nut on top of solenoid. 	<ol style="list-style-type: none"> 1. Brewer should be connected to cold water line. 2. Adjust as necessary. 3. If water pressure is over 90 PSI install a pressure regulator and adjust to 50 PSI. 4. This not the fault of the brewer and can usually be corrected by rearranging some plumbing or adding an air chamber to the incoming water line. 5. Nut should be tight. Tighten as required.

TROUBLE SHOOTING GUIDE CONTINUED

SYMPTOM	POSSIBLE CAUSE	WHAT TO CHECK	REMEDY
FAUCET DRIPPING (FAUCET MODELS)	1. Clogged valve seat.	1. Valve seat.	1. Disassemble and clean or replace as required.
FAUCET WATER FLOW TOO FAST OR TOO SLOW (FAUCET MODELS)	1. No water. 2. Flow too slow or too fast.	1. (A) Incoming water line shut off valve. (B) Faucet clogging. (C) Needle valve. 2. Needle valve.	1. (A) Water shut off valve should be open. (B) Clean or rebuild faucet. (C) Needle valve should be open. 2. Increase flow by turning needle valve counter clockwise, decrease flow by turning clockwise.

COMPONENT REPLACEMENT INSTRUCTIONS

CAUTION: DISCONNECT BREWER CORD FROM ELECTRICAL OUTLET BEFORE REMOVAL OF ANY PANEL OR REPLACEMENT OF ANY COMPONENT!

NOTE: IN CANADA REPAIRS ARE TO BE DONE BY CERTIFIED ELECTRICIAN OR BREWER MUST BE RE INSPECTED TO MAINTAIN APPLICABLE CERTIFICATION

These steps apply to replacement of tank, tank heater, faucet coil, and hi-limit or main thermostat.

1. Remove sprayhead and sprayhead nut by unscrewing in counter clockwise direction.
2. Remove brewer lid. Disconnect electrical connectors from upper warmer plate if applicable.
3. Remove slotted receiving pan nut. Remove receiving pan by raising the front of the pan while simultaneously pulling forward to clear the inlet tube.
4. Disconnect electrical terminals connected to tank element. Disconnect black lead from main thermostat.
5. Disconnect the inlet to coil and coil to faucet tubes from attached fittings, if applicable.
6. Lift tank completely out of brewer.

TANK ASSEMBLY

7. To install new tank ass'y, reverse steps 6 through 1 above.

THERMOSTAT, HI-LIMIT

1. Disconnect wires to hi-limit thermostat.
2. Lift retaining spring slightly to remove old hi-limit thermostat.
3. Check continuity of the new hi-limit thermostat before installing.
4. Slide new hi-limit thermostat into place under the retaining spring. Reconnect wire leads.
5. Insure that hi-limit thermostat is securely mounted & all electrical connections are tight and isolated.

THERMOSTAT, MAIN

1. Remove two screws which secure thermostat to bracket.
2. Remove grommet from top of tank lid by pressing up with thumb. Pull capillary bulb out through hole.
3. Disconnect thermostat wires.
4. Installation is reverse of removal.

ELEMENT, TANK HEATING

1. Remove the 8 tank lid retaining nuts. Lift tank lid assembly out of tank.
2. Disconnect wire leads from the tank element.
3. Remove the 2 brass nuts, on top side of tank lid, from tank element. Remove element.
4. Install the new tank heating element, washers, and nuts. Tighten securely to insure proper sealing.
5. Inspect tank lid gasket and replace if necessary.
6. Assemble by reversing steps 2 through 1.

COMPONENT REPLACEMENT INSTRUCTIONS, CONTINUED

HOT WATER COIL (FAUCET MODELS)

1. Remove the 8 tank lid retaining nuts. Lift tank lid assembly out of tank.
2. Remove the 2 compression nuts from top of hot water coil and remove old coil.
3. Installation is reverse of removal.

WARMER ELEMENT

1. Remove retaining screws from warmer plate.
2. Lift plate and disconnect leads.
3. Remove nuts and washers holding retaining plate and warmer element to plate.
4. Installation is reverse of removal.

FAUCET ASSEMBLY

1. Follow steps 1-3 above for removing receiving pan.
2. Disconnect tank to faucet water line from faucet fitting.
3. Remove stainless steel nut and washer from faucet fitting.
4. Pull out faucet ass'y from front of brewer. Reverse steps for installation of new faucet.

TIMER ASSEMBLY

1. Disconnect timer plug from timer.
2. Remove retaining screws from timer.
3. Remove timer.
4. Installation is reverse of removal.

SOLENOID

1. Disconnect wire leads from solenoid coil.
2. Disconnect brass fitting from inlet side of solenoid assembly.
3. Disconnect brass fitting from outlet side of solenoid assembly.
4. Remove solenoid.
5. Install solenoid insuring proper flow:
 - Solenoid with an arrow - arrow points toward left side of brewer.
 - Solenoid with ports labeled IN and OUT - IN port connected to incoming water line.
6. Installation is reverse of removal.

FLOW CONTROL

1. Disconnect lower brass fitting on flow body.
2. Disconnect upper brass fitting on flow body.
3. Remove flow body.
4. Install flow body insuring arrow points towards the top of the brewer.
5. Installation is reverse of removal.

BREW START AND WARMER SWITCHES

1. Remove wire leads from terminals on switch.
2. Remove switch by pressing tabs in while pushing switch out towards front of brewer.
3. Installation is reverse of removal.

LIMING

To prevent liming problems in tank fittings remove sprayhead and insert deliming spring all the way into the tank. When inserted into tank properly, no more than ten inches of the spring should be visible at the sprayhead fitting. Saw back and forth five or six times. This will keep fittings open and clear of lime. In hard water areas this should be done everyday. This process takes approximately one minute. In all areas the sprayhead should be cleaned at least once a week. Where bad liming has already occurred, a new complete tank assembly may be installed. The tank may be changed in approximately 5 minutes time.

GK SERIES PARTS LIST - (See pictorial on fold out page)

Index	Part No	Description	Index	Part No	Description
1	705229	GKF-1 cover, assembly	36	705634	GK front panel, dual
1	705414	GKF-2 cover, assembly	37	705224	Brace, front panel, single
1	705420	GKF-3 cover, assembly	37	705632	Brace, front panel, dual
1	705591	GKDF-2 cover assembly	38	701279	Rail, L.H.
1	705592	GKDF-4 cover assembly	39	701280	Rail, R.H.
1	705541	GKDF-6 cover assembly	40	705295	Brew basket assembly, black
1	705414	GK 1 station cover ass'y w/ pour in	41	700464	Base ass'y, single
1	705420	GK 2 station cover ass'y w/ pour in	41	700480	Base ass'y, dual
2	100010	Warming plate assembly, black, 100W 120V	42	100010-10	Warming plate assembly, black, 120W 120V
3	100008	Plate, black porcelain	43	202053	Element, warmer 120W 120V
4	100187	Element, warmer 100W 120V	44	700454	Base top, single
5	100086	Support plate, warming element	44	700449	Base top, dual
6	100197	Tinnerman clip, #8	45	700459	Base trim plate, single
7	700198	Dust cover, front pour in	45	700460	Base trim plate, dual
8	700186	Wire for dust cover	46	700456	Base bottom , single, spotwelded
9	705401	GK automatic tank ass'y 1700W 120V	46	700451	Base bottom, dual, spotwelded
9	705402	GK faucet tank ass'y 1700W 120V	47	100078	Foot, bumper with screw
9	705403	GK pour over tank ass'y 1700W 120V	48	704103	Tinnerman nut, retainer
9	705408	GK automatic tank ass'y 2500W 240V	49	100542	Leg, black plastic 4"
9	705660	GK faucet tank ass'y 2500W 240V, L.H.	50	100003	Snap bushing, 3/4, plastic
9	705661	GK faucet tank ass'y 2500W 240V, R.H.	51	701200	Slotted hex nut, 3/4-16, brass
9	705677	GK pour over tank ass'y 2500W 240V	52	700015	Washer, 1" OD x 3/4, S/S
10	704223	Bushing, siphon cup	53	700060	Basin, pour in
11	704222	Gasket, delivery tube, 3 hole	54	700016	Gasket, 1.062 OD X .578, silicone
12	700069	Sprayhead tube assembly	55	100025	Gasket, sprayhead
13	100175	Grommet, thermostat, silicone	56	100190	Jam nut, 1/2-20, brass
14	705595	Copper tube 1/4" OD x 11.38"	57	100143	Bracket, hi-limit thermostat
15	705381	Tube, 1/4" OD x 4.0" x 10.75", copper	58	767110	Valve, needle, angle, 1/4 flare
16	102299	Main thermostat, knob type	59	100633	Hi-limit thermostat, manual reset
17	100177	Elbow, male 1/4F x 1/8	59	100174	Hi-limit thermostat, auto reset
18	705398	GK automatic tank lid ass'y 1700W 120V	60	101720	Connector, 3/8C x 1/8P, female
18	705400	GK faucet tank lid ass'y 1700W 120V	61	100030	Gasket, .566"ID x .811"OD, brass
18	705399	GK pour over tank lid ass'y 1700W 120V	62	100409	Gasket, .515"ID x .811"OD, brass
18	705405	GK automatic lid ass'y 2500W 240V	63	100431	Nut, 9/16-24, brass
18	705659	GK faucet tank lid ass'y 2500W 240V, L.H.	64	704221	Gasket, tank, silicone
18	705658	GK faucet tank lid ass'y 2500W 240V, R.H.	65	704119	Tank only
18	705678	GK pour over tank lid ass'y 2500W 240V	66	705379	Tube, 13" discharge, S/S
19	705214	GK automatic / pour over tank lid, spotwelded	67	705208	GK rear panel, single
19	705218	GK faucet tank lid, spotwelded	67	705635	GK rear panel, dual
20	705198	Bracket, main thermostat	68	705197	Cabinet shell ass'y, single
21	100043	Thermostat knob	68	705639	Cabinet shell ass'y, dual
22	771031	Coil assembly	69	102126	Power cord, 12/3, 120V 20A
23	704155	Main Element, 1700W 120V	69	100072	Power cord, 10/4, 240V 30A
23	704144	Main Element, 2500W 240V	70	100547	Strain relief, 120V 20A
24	100176	Connector, male, 1/4F-1/4F	70	511054	Strain relief, 240V
25	511046	Washer, 7/16" int tooth S/S	71	511006	Cord plate, 120V 20A
26	100281	Plug, 3/8", plastic	71	511007	Cord plate, 240V
27	700519	Switch plate, GKF-1	72	100163	Terminal block, 120 V
27	700522	Switch plate, GKF-3	72	511053	Terminal block, 240 V
27	700406	Switch plate, GKDF-2	73	511023	Nut, 7/16-20, 11/16 hex, brass
27	700329	Switch plate, GKDF-4	74	705228	Snap bushing, 1-1/8", plastic
27	700328	Switch plate, GKDF-6	75	705337	Tube, 1/4" OD x 1.437", S/S
28	100058	Nameplate, NEWCO	76	511063	Flow control assembly
29	100145-10	Faucet, Tomlinson with flare	77	705338	Tube, 1/4" OD x 1.21" x 1.50", S/S
30	100085	Rocker switch, ON/OFF, lighted	78	100161	Tube, 1/4" OD x .88", copper
31	201985	Start switch, rectangular	79	704190	Melitta adapter, single, spotwelded
32	201162	Switch, toggle	79	700471	Melitta adapter, dual, spotwelded
32	100131	Nut, toggle switch	80	201132	Tee, 1/4" flare
33	704140	Timer, Multi Brew	81	705390	Solenoid assembly
34	201173	Nut, sprayhead	82	100255	Valve, solenoid
35	100024	Sprayhead, 5 hole	83	100154	Connector, male, 1/4"F x 1/8"
36	705210	GK front panel, single	84	705596	Tube, solenoid supply, copper

EXPLODED VIEW DRAWING (GKF-3 SHOWN)

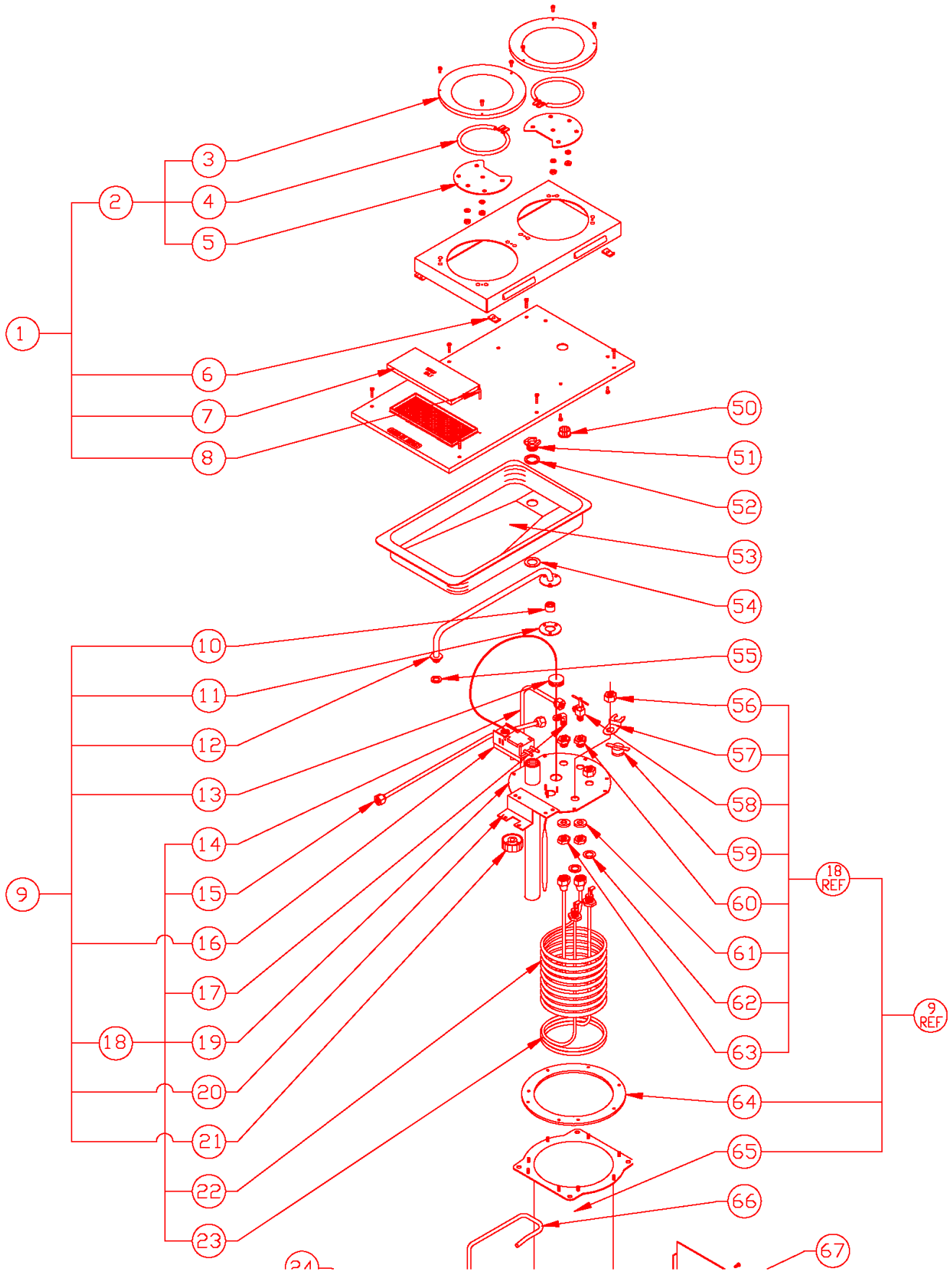

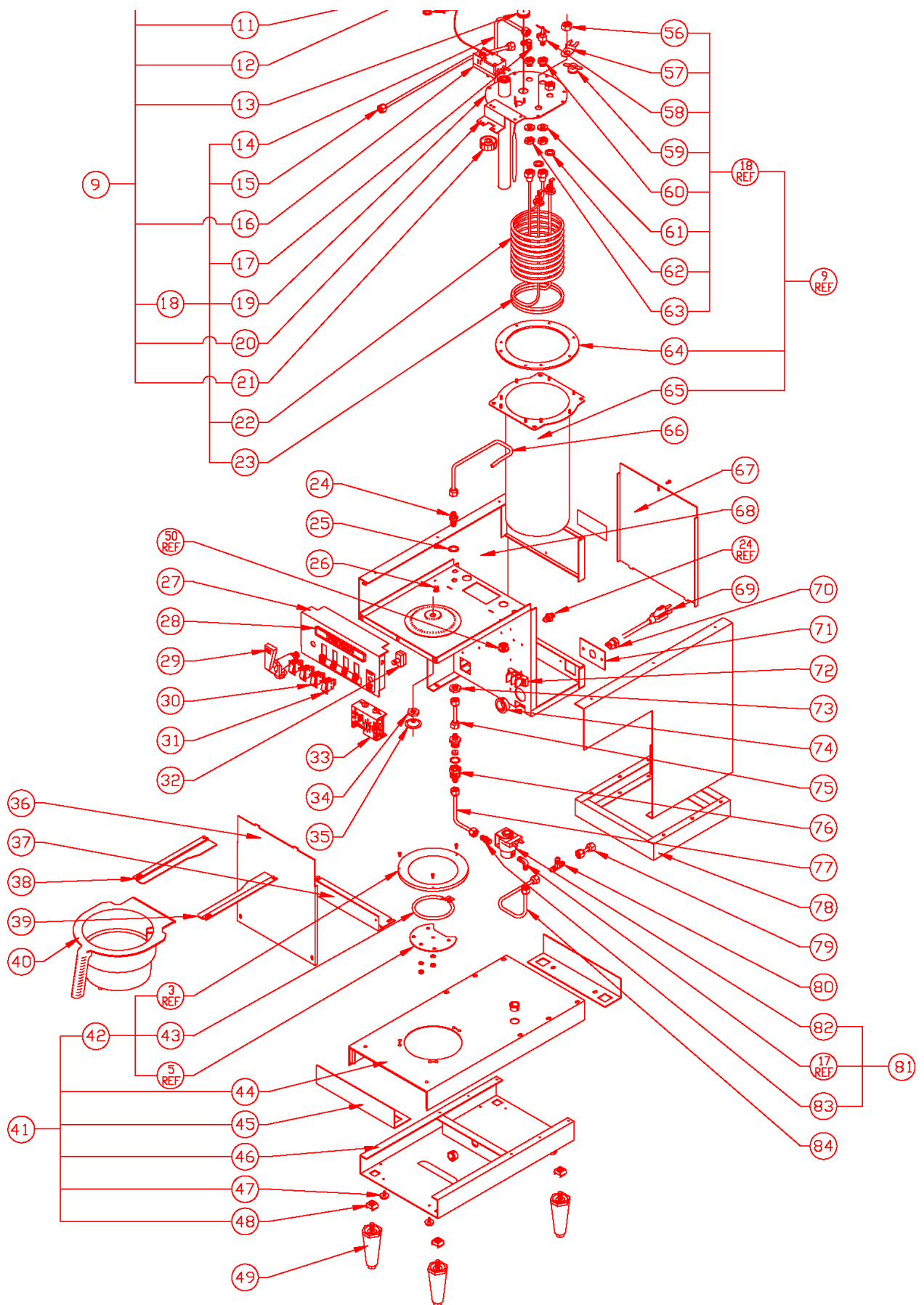

WIRING DIAGRAMS

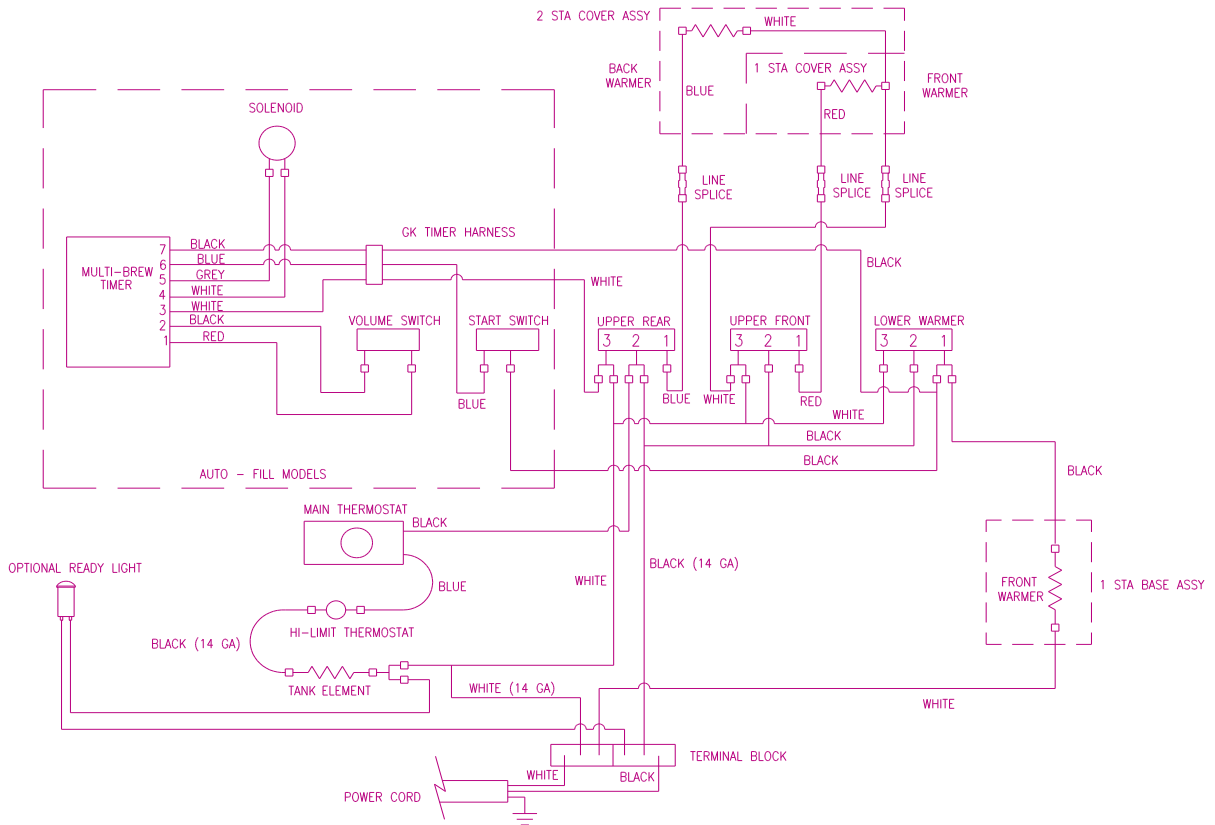

GK Series Brewer - 120 V

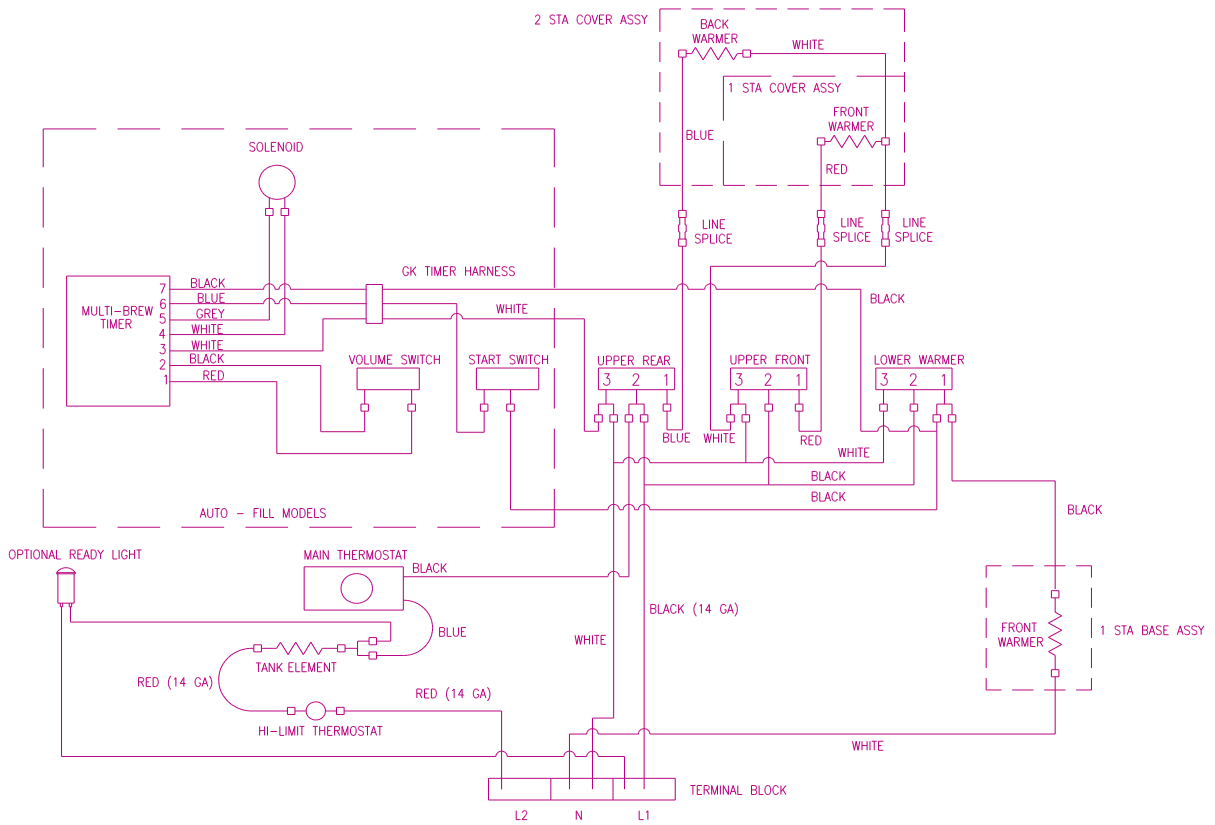

GK Series Brewer - 120 V / 240 V

Newco Enterprises, Inc. * 1735 South River Rd. * P.O. Box 852 * St. Charles, MO 63303