

# FRONT LOAD POST MIX URN

ICED COFFEE



Newco's front access post mix dispensers. Designed and built with high quality components and easy set up & ratio adjustments. Newco dispensers deliver consistent drinks with every dispense. Reduce labor, eliminate waste and increase profits with the Newco's post mix dispensers.

## Features

- New narrow design frees up valuable counter top space for other beverages.
- 1 product dispenser accommodates up to one 3-Gal BIB.
- 2 product dispenser accommodates two 1/2 Gal BIBs.
- New low profile design is perfect for offices and locations with height restrictions under 18".
- Mechanical (non-electric) operation.
- Only 25 PSI static waterline pressure required.
- High quality, Stainless steel construction for years of trouble free service.
- Simple drink strength adjustment.
- Water pressure regulator to ensure drink taste consistency.
- Comes equipped with QCD connection (Scholle Connector optional)
- Rear shutoff valve.
- Custom branding and wraps of the dispensers available through Newco.



706661  
Coffee, Front Load, 2 Faucet

# Front Load Iced Coffee

## Plug and Play Operation

Simply connect the front loader to a 1/4" flare water connection.

## Custom Branding

Front load series can be custom branded with your image helping you to promote your brand and services.

## Post Mix Urn

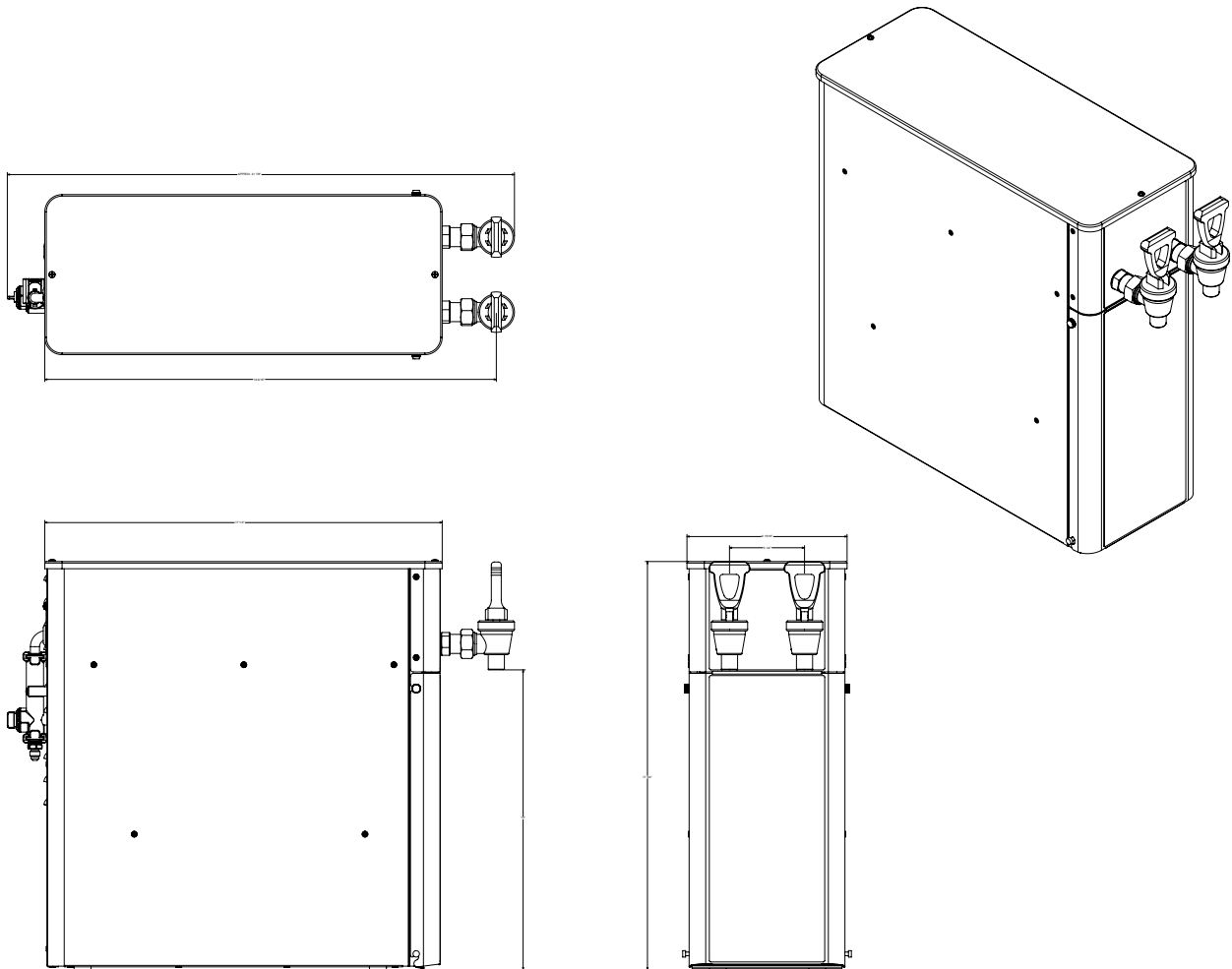

## Additional Information

| Part Number | Height   | Width   | Depth    | Volts | Watts | Amps | Weight |
|-------------|----------|---------|----------|-------|-------|------|--------|
| PN: 706661  | 17.6875" | 6.9375" | 21.5625" | N/A   | N/A   | N/A  | 26 lbs |