

# CUP COMPANION

MOTION ACTIVATED



**TOUCHLESS**  
SOLUTIONS



## Features

- Touchless technology.
- Space saving compact design fits under most cabinets.
- 3 separate hoppers.
- Substantial savings over individual packets.
- Eliminates pilferage and waste.
- Accelerates beverage preparation.
- Shelf-stable powder products.
- 2 pound capacity hoppers
- Programmable 1/10 second portions (approx. 1 tsp) control and motion activated dispensing features.
- Accommodates most cup sizes with use of optional 4" legs.
- Motion activated dispensing.

Love coffee, just not straight black? Well now you can add your favorite sweetener or creamer without even touching a button.

Newco's Cup Companion Dispenser fits next to your coffee brewer, creating a flavor station. This allows your customers to flavor their coffee with a wide variety of sweeteners including but not limited to cream and sugar without touching the machine.

The flavor dispenser uses motion activated technology allowing customers to forgo touching the machine. Place the cup on the drip tray under the desired flavor, the cup will trip the sensor to dispense the powder, then remove and enjoy. If you would like to add a different flavor or receive another serving place cup back on the drip tray under the flavor.

# Cup Companion

## Plug and Play Operation

Simply plug in the Cup Companion and it is ready for use.

## Custom Branding

Cup Companion's entire front can be custom branded with your image helping you to promote your brand and services.

## Dimensions

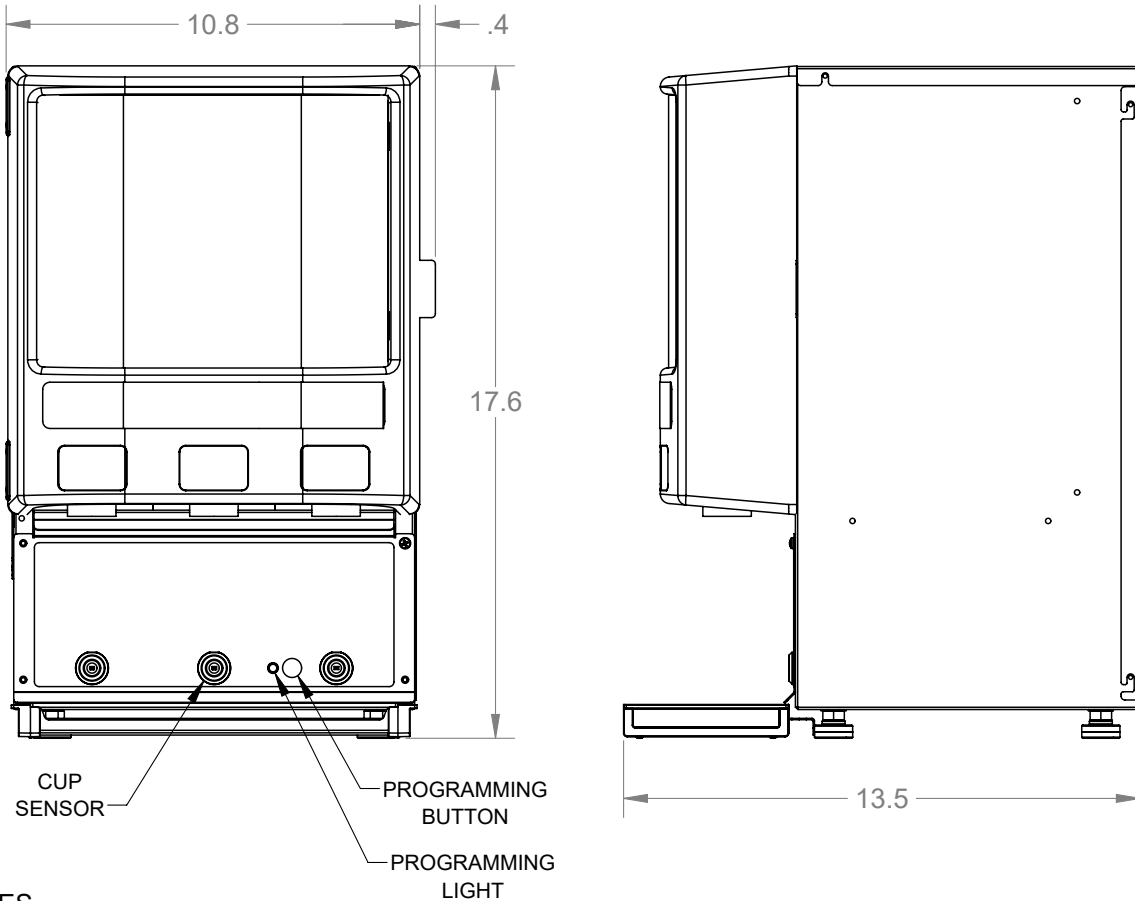

### CAPACITIES

Product canisters hold 2 LBS +, dependent on product. 3 canisters included.

### ELECTRICAL RATING

120 V AC, 3A

## Additional Information

Item #	Model	Height	Width	Depth	Ship Wt.	Volts	Amps
782020	Cup Companion	17.6	10.8	13.5	20 lbs	120	15.0