

COLD BREW MANUAL

NEWCO ENTERPRISES INC,
3650 NEW TOWN BLVD SAINT CHARLES, MO 63301
1-800-325-7867



*Cold Brew Stand
PN 805044
Shown with
2 Gallon Dispenser*



*Cold Brew 2 Gallon Brewer
PN 123385
Cold Brew 2 Gallon Dispenser
PN 123383*



*Cold Brew 3.5 Gallon Brewer
PN 123363
Cold Brew 3.5 Gallon Dispenser
PN 123351*

NEWCO CONTACT INFORMATION

ADDRESS

NEWCO ENTERPRISES INC,
3650 NEW TOWN BLVD
SAINT CHARLES, MO 63301

CUSTOMER SERVICE PHONE

1-800-325-7867

TECHNICAL SERVICE PHONE

1-800-556-3926

FAX

1-636-925-0029

WEBSITE

newcocooffee.com

CUSTOMER SERVICE AND SALES EMAIL

sales@newcocooffee.com

MAINTENANCE INFORMATION

Machine Model _____

Company Information and Phone Number

TABLE OF CONTENTS

- WARRANTY** ----- 4
- SPECIFICATIONS** ----- 5
- MACHINE SET UP** ----- 6
- MACHINE OPERATION**
 - HOW TO BREW ----- 7
 - CLEANING ----- 8
- MACHINE PROGRAMMING**
 - SERVICE MODE ----- 9
 - USER MODE ----- 10
- SERVICING THE MACHINE**
 - ERROR MESSAGES ----- 11
 - WIRING DIAGRAM ----- 11
 - REPLACEMENT PARTS ----- 12

WARRANTY

This warranty supersedes all other previous warranties that are currently in manuals. Newco warrants equipment manufactured by it for 1-year parts and labor. Accessories, Dispensers, and Display Tablets - 1 Year parts only. Electronic Circuit and Control Boards- 3 years parts, 1 year labor. Equipment manufactured by others and distributed by Newco- please see original equipment manufacturers warranty, Newco will follow.

These warranty periods run from the date of sale Newco warrants that the equipment manufactured by it will be commercially free of defects in material and workmanship existing at the time of manufacture and appearing within the applicable warranty period. This warranty does not apply to any equipment, component or part that was not manufactured by Newco or that, in Newco's judgment, has been affected by misuse, neglect, alteration, improper installation or operation, relocation or reinstallation, improper maintenance or repair, incorrect voltage applied to the unit at any time, damage or casualty. This warranty does not apply to any equipment failures related to poor water quality, excessive lime and chlorine and non-periodic cleaning and descaling. Warranty is null and void if muriatic or any other form of hydrochloric acid is used for cleaning or deliming. In addition, this warranty does not apply to replacement of items subject to normal use including but not limited to user replaceable parts such as faucet seat cups, sight gauge tubes, washers, o-rings, tubing, seals and gaskets.

This warranty is conditioned on the Buyer 1) giving Newco prompt notice of any claim to be made under this warranty by telephone at (800) 556-3926 or by writing to **3650 New Town Blvd, Saint Charles, MO 63301**; 2) if requested by Newco, shipping the defective equipment prepaid to an authorized Newco service location; and 3) receiving prior authorization from Newco that the defective equipment is under warranty.

THE FOREGOING WARRANTY IS EXCLUSIVE AND IS IN LIEU OF ANY OTHER WARRANTY, WRITTEN OR ORAL, EXPRESS OR IMPLIED, INCLUDING, BUT NOT LIMITED TO, ANY IMPLIED WARRANTY OF EITHER MERCHANTABILITY OR FITNESS FOR A PARTICULAR PURPOSE. The agents, dealers or employees of Newco are not authorized to make modifications to this warranty or to make additional warranties that are binding on Newco. Accordingly, statements by such individuals, whether oral or written, do not constitute warranties and should not be relied upon.

If Newco determines in its sole discretion that the equipment does not conform to the warranty, Newco, at its exclusive option while the equipment is under warranty, shall either 1) provide at no charge replacement parts and/or labor (during the applicable parts and labor warranty periods specified above) to repair the defective components, provided that this repair is done by a Newco Authorized Service Representative; or 2) shall replace the equipment or refund the purchase price for the equipment.

THE BUYER'S REMEDY AGAINST NEWCO FOR THE BREACH OF ANY OBLIGATION ARISING OUT OF THE SALE OF THIS EQUIPMENT, WHETHER DERIVED FROM WARRANTY OR OTHERWISE, SHALL BE LIMITED, AT NEWCO'S SOLE OPTION AS SPECIFIED HEREIN, TO REPAIR, REPLACEMENT OR REFUND.

In no event shall Newco be liable for any other damage or loss, including, but not limited to, lost profits, lost sales, loss of use of equipment, claims of Buyer's customers, cost of capital, cost of down time, cost of substitute equipment, facilities or services, or any other special, incidental or consequential damages.

WARNING: *Read and follow installation instructions before plugging or wiring in machine to electrical circuit. Warranty will be void if machine is connected to any voltage other than that specified on the serial tag. Machine must be plugged into a grounded outlet.*

SPECIFICATIONS

2 GALLON

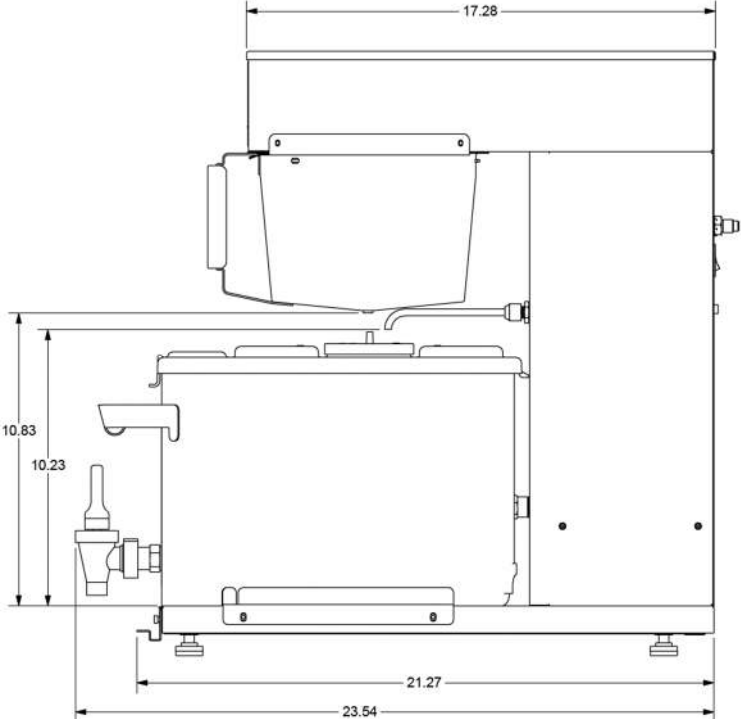
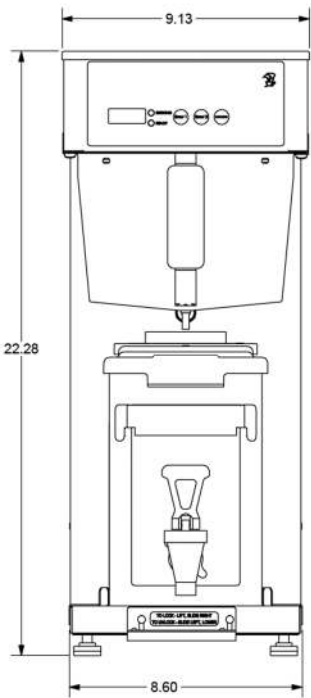

3.5 GALLON

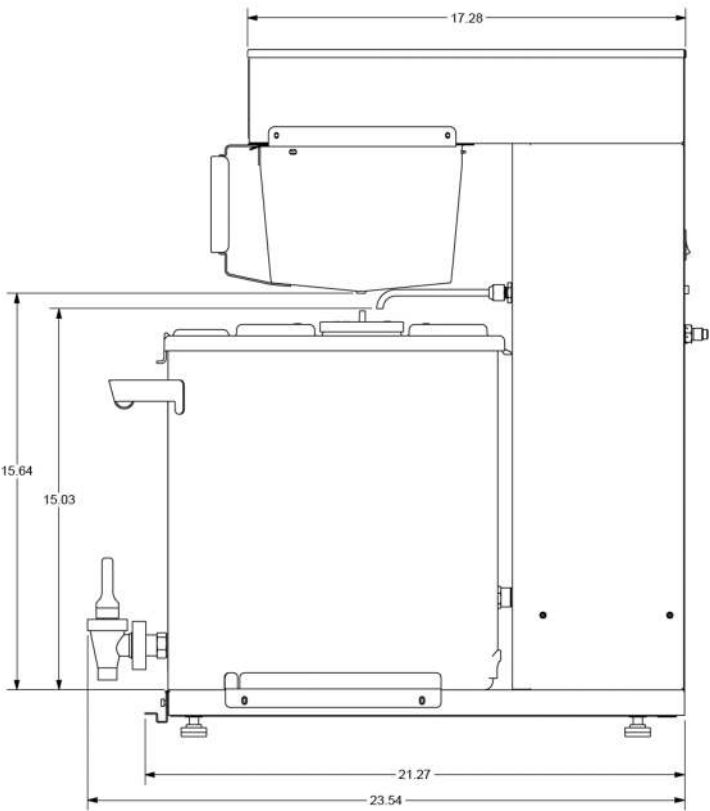
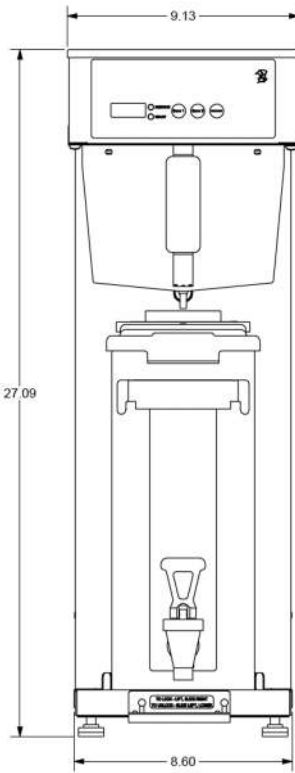

MACHINE SET UP

Note: The 2 gallon machine weighs approximately 41lbs. The 3.5 gallon machine weighs approximately 43lbs. Use caution when unpacking and lifting machine.

CAUTION: Do not turn on machine power until specified in Set Up Instructions.

PLUMBING

1. Brewer must be installed to comply with all applicable federal, state, and local plumbing codes and ordinances.
2. Flush water line before installing brewer.
3. Connect cold water line to the ¼" flare fitting on rear of brewer.
4. Turn on water supply and check for leaks.

ELECTRICAL

1. Ensure power switch is in the off position, "O". The power switch is located on the rear of the machine.
2. Plug the included power adaptor into a 120 V AC receptacle.
3. Plug the barrel connector end of power supply into the receptacle on the back of the unit near the power switch.
4. Turn the power switch to the on position, "I", to begin using your machine.



Do not use alternate power adapters.

The included power adapter is a switching type adapter with a rated output of 12 V DC, 3 A. The barrel connector is a 5.5×2.1 mm plug, with the center pin having positive polarity.

Refer to data plate for electrical requirements.

Data Plate Example:

Data Plate is located on near the bottom of the right side panel.

MANUFACTURED BY: NEWCO ENTERPRISES INC. ST CHARLES, MO 63301					
MFG DATE		06/02/21	MF		
120	VOLTS A C	2	AMP	20	WATTS
1	PHASE	3	WIRE	60	HERTZ
Product Patents & Patent Information:					
SERIAL NO. Serial Number Here					
					
Serial Number Here					
MODEL Model Name Here					
					
Model Name Here					

MACHINE OPERATION

HOW TO BREW

1. In order to place the dispenser under the brew basket, the retainer bracket on the front of the machine must be in the lowered position. If the retainer is in the raised position, push bracket up, then to the left, then down, as shown in images 1, 2, 3, and 4.



Image 1

“raised position”



Image 2



Image 3



Image 4

“lowered position”

2. Slide clean, empty dispenser between the guide rails on brewer base. The dispenser will interface with the plumbing fitting on the brewer’s column. Move retaining bracket to the raised position by reversing the movements in Step 1. The bracket must be in the raised position for the dispenser to properly connect to the plumbing fitting. Ensure strainer (PN 124002) is attached to plumbing interface inside of the dispenser (Image 5). Order a silicone elbow and clamp (PN 781879 with PN 111635) for smaller brew volumes.
3. Place a paper filter (PN 109140, size 15.5"×5.5") into the brew basket and add the appropriate amount of ground coffee. Slide the basket onto the brew rails.



Image 5

4. Once the green light on the front of the brewer is on, the machine is ready to brew. Press the button corresponding to the desired recipe.
5. The brewer will fill the dispenser with the programmed water volume. Once the dispenser has filled, the internal pump will begin to draw the cold water from the dispenser, through the machine, then over the bed of coffee in the brew basket. This is the brewing process, it will repeat many times throughout the brew cycle.
6. The display will count down the brew time in hours: minutes until under 10 minutes remain. Once less than 10 minutes remain in the brew cycle, the display will count down in minutes: seconds. The visa brew time, which allows for the coffee to finish dripping after a brew cycle is completed, will count down in minutes: seconds. A beeper will sound at the end of the cycle to alert the user that the product is ready.
7. An amber light will flash while the machine is brewing. To cancel a brew cycle, press any button on the front of the machine.
8. Once brewing is complete, remove the dispenser and place on a stand for serving. Remove brew basket from rails, empty, then rinse the basket so it is ready for the next brew. Wipe the spray head and brew plate area with a clean cloth, then slide the basket back into place. The coffee brewer must undergo a daily cleaning cycle to remove any residual coffee from the internal pump and tubing of the brewer. See instructions below.

Note: after running a Rinse or Cleaning cycle, be sure to empty the dispenser.

CLEANING INSTRUCTIONS

BREWER

1. Ensure liquid has finished draining from brew basket.
2. Remove the dispenser by lowering the retainer on the brewer base. Drain any remaining liquid into a sink. Put the empty dispenser back on the brewer base and lock into place.
3. Remove basket from brewer and empty spent grounds and paper filter into waste bin.
4. Rinse any remaining coffee particles from the basket.
5. Place paper filter inside of basket.
6. Pour one packet of "Urnex Urn and Brewer Cleaner" into paper filter, or 0.5 oz of "Urnex Clearly Cold" liquid cleaner into the dispenser.
7. Wipe spray head and brew plate clean and replace basket into the brewer.
8. Press the "Clean" button on brewer to start the cleaning cycle.
 - a. Brewer will fill the dispenser with water. A beep will sound when fill is complete and begin a 5-minute countdown allowing for time to add or dissolve chemicals for those using an alternate process. A beeper will periodically sound to alert user to complete this step.
9. Press the clean button again to skip the delay period. The cycle will automatically continue after 5 minutes of no user interaction.
 - a. The brewer will then circulate the cleaning solution throughout the system.
10. After the pump has finished, water will continue to drain from the basket.
11. A countdown timer will be displayed, and the amber brewing light will be lit during each phase of the cleaning process. A beeper will sound, and the green ready light will be lit when cleaning portion of cycle is complete.
12. Once complete, unlock the dispenser to remove it from the brewer base and drain into sink.
13. Remove and dump used coffee filter. There may be some cleaner residue left in the coffee filter, that is to be expected. Replace the brew basket in the machine.
14. Replace empty dispenser onto brewer base and lock into place.
15. Press "Rinse" button on brewer.
16. Brewer will fill dispenser with water and begin to recirculate and rinse throughout the system.
17. Once complete, unlock dispenser to remove it from the brewer base and drain into sink.
18. Replace empty dispenser onto brewer base and lock into place.

To cancel a clean cycle, press either the left or the center button.

FAUCET AND DISPENSER SANITIZATION

1. Remove the faucet from the coffee dispenser by unscrewing the wing nut securing the faucet body to the shank. Disassemble the faucet bonnet from the body. Scrub the faucet parts with hot soapy water and rinse with clean hot water.
2. Create a solution of 50 ppm of chlorine and water. Place handle parts in solution for 1 minute to sanitize.
3. Reassemble faucet and reattach to dispenser.
4. Wash the outer surface of dispenser with a clean damp cloth.

System is now clean and ready for brewing.

MACHINE PROGRAMMING

The Cold Brew Coffee Brewer has two program modes: Service Mode and User Mode. The Service Mode is used to establish basic operating parameters of the unit while the User Mode allows the three buttons to be programmed for recipes and cleaning. Programming modes are initiated as outlined below. The screens will loop continuously until exiting the mode by selecting End when it is displayed.

SERVICE MODE

Service Mode is entered by holding any two of the buttons on the face of the machine while powering up the brewer. The brewer firmware revision number is displayed for a couple of seconds when entering this mode. Use Button 2 (center) to advance through the items and Buttons 1 and 3 to decrease or increase the values/selection respectively.

END OF CYCLE BEEPER

Allows user to turn beeper on or off. When on, the beeper will sound to indicate a brew cycle has completed.



BREW PUMP SPEED

This sets the speed of the water pump used for brewing or cleaning. Values are between 1 and 10, with the default set to 5.

Finer grinds should have this slowed to 1-3 for proper water flow.



COLD CALIBRATION

In this selection, when either the left or right button is pressed, the machine will dispense water for a valve calibration. Place a measuring container below the the fill tube, located behind the brew basket, before starting the calibration process.

Note: if the machine has not been run at all, run this process twice. The first run will prime the system to ensure accurate flow rate.



COLD CALIBRATION VOLUME

Adjust this setting to match the number of ounces delivered during the Cold Calibration process. Values range from 20-150. The ideal outcome is between 28 and 34 oz.

BREW COUNTER

This screen shows the number of brew cycles the machine has gone through, up to 999 cycles.

END

When this option is displayed, the user may press either the left or the right button to exit Service Mode. If the center button is pressed, the display will return to the End of Cycle Beeper setting.

USER MODE

User Mode is entered by holding any one of the buttons on the face of the machine while powering up the brewer. The brewer firmware revision number is displayed for a couple of seconds when entering this mode. There are 3 parameters for each of the 3 buttons. The display will show each set of parameters in order, starting with b1.

Press the center button to advance through the parameters, and the left and right buttons to adjust the displayed setting.

After the final parameter for b3 is shown, "End" will be displayed. Pressing either the left or the right button will end User Mode, while pressing the center button will return to the parameters for b1.

Button	Description	Parameter	Range		Description
			2 Gallon	3.5 Gallon	
1/ Left/ b1	Used for main brew recipe	Volume	30-640 oz		Allows user to set the number of ounces to be dispensed
			Ideal: 220oz	Ideal: 270oz	
		Time	0:05-4:00 (Hrs:Mins) Ideal: 1:15		Time for liquids to circulate through the machine.
		Visa Brew Time	0:00-6:00 (Mins:Secs) Ideal: 5:00		Time to allow any liquids to finish dripping
2/ Center/ b2	Used for rinse cycle, can be programmed as a second brew recipe	Volume	30-640oz		Allows user to set the number of ounces to be dispensed
			Ideal: 240oz	Ideal: 320oz	
		Time	0:05-4:00 (Hrs:Mins) Ideal: 0:05		Time for liquids to circulate through the machine.
		Visa Brew Time	0:00-6:00 (Mins:Secs) Ideal: 4:00		Time to allow any liquids to finish dripping
3/ Right/ b3	Cleaning Cycle <i>Should not be used for brewing, as it has a special function intended only for cleaning.</i>	Volume	30-640 oz		Allows user to set the number of ounces to be used for cleaning
			Ideal: 220oz	Ideal: 270oz	
		Time	0:05-4:00 (Hrs:Mins) Ideal: 0:05		Time allowed for machine cleaning cycle.
		Visa Brew Time	0:05-4:00 (Mins:Secs) Ideal: 4:00		Time to allow any liquids to finish dripping

Note: after running a Rinse or Cleaning cycle, be sure to empty the dispenser.

SERVICING THE MACHINE

ERROR MESSAGES

Any errors that do not automatically clear themselves may be reset by turning power off then back on using switch on the rear of unit.

ERROR 1/2/3

Program 1/2/3 has a bad value or cannot be read- this will reset the settings to default values in programming.

Default volumes are 220 oz, 320 oz, and 270 oz for b1, b2, and b3, respectively.

Default times match ideal times in the table on page 10.

ERROR 5

Parameters either read out wrong, or were corrupted on startup. Restart machine. If this error appears again, replace control board (PN 123336).

WIRING DIAGRAM

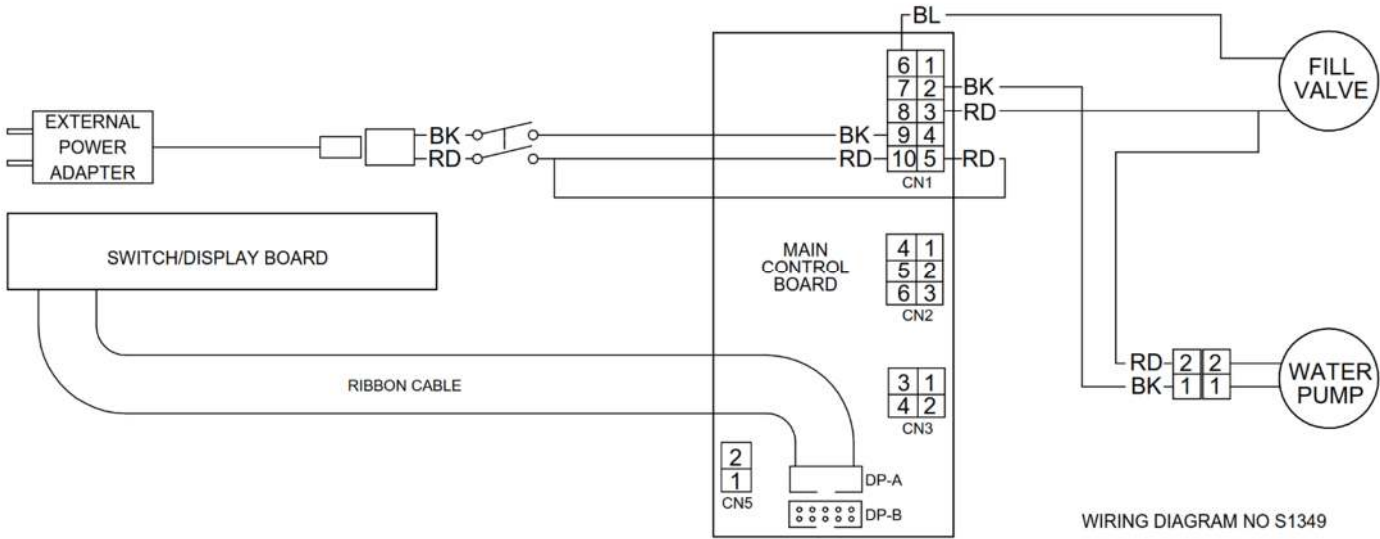

TYPICAL REPLACEMENT PARTS

STAND ONLY

PN 805044

2 GALLON DISPENSER ONLY

PN 123383

3 GALLON DISPENSER ONLY

PN 123351

BREW BASKET

PN 123359 – 15" × 5" Cold Brew Basket

BASKET FILTERS

PN 109140 – 15" × 5.5" Coffee Filter

DISPENSER SCREEN

PN 124002 - Screen Filter Kit

PC BOARD

PN 123336 - Control Board

VALVE

PN 123346 - Solenoid Valve

PUMP

PN 109939 - Gear Pump

DISPLAY BOARD

PN 123365

POWER SUPPLY

PN 123347

FACEPLATE LABEL

PN 123398 - Newco Front Panel Label

RETAINER BRACKET

PN 123324 - Used with screws PN 900664



Image: 3.5 Gallon Dispenser



Image: Brew Basket



Image: Faceplate Label

Images taken on a 1 inch grid

Page intentionally left blank