

# LCD TOUCH

NEWCO ENTERPRISES INC,  
3650 NEW TOWN BLVD SAINT CHARLES, MO 63301  
1-800-325-7867



# NEWCO CONTACT INFORMATION

## ADDRESS

NEWCO ENTERPRISES INC,  
3650 NEW TOWN BLVD  
SAINT CHARLES, MO 63301

## CUSTOMER SERVICE PHONE

1-800-325-7867

## TECHNICAL SERVICE PHONE

1-800-556-3926

## FAX

1-636-925-0029

## WEBSITE

[newcocooffee.com](http://newcocooffee.com)

## CUSTOMER SERVICE AND SALES EMAIL

[sales@newcocooffee.com](mailto:sales@newcocooffee.com)

# MAINTENANCE INFORMATION

Machine Model \_\_\_\_\_

Serial Number \_\_\_\_\_

Company Information and Phone Number

\_\_\_\_\_

\_\_\_\_\_

\_\_\_\_\_

\_\_\_\_\_

# WARRANTY

*This warranty supersedes all other previous warranties that are currently in manuals. Newco warrants equipment manufactured by it for 1-year parts and labor. Accessories, Dispensers, and Display Tablets - 1 Year parts only. Electronic Circuit and Control Boards- 3 years parts, 1 year labor. Equipment manufactured by others and distributed by Newco- please see original equipment manufacturers warranty, Newco will follow.*

These warranty periods run from the date of sale Newco warrants that the equipment manufactured by it will be commercially free of defects in material and workmanship existing at the time of manufacture and appearing within the applicable warranty period. This warranty does not apply to any equipment, component or part that was not manufactured by Newco or that, in Newco's judgment, has been affected by misuse, neglect, alteration, improper installation or operation, relocation or reinstallation, improper maintenance or repair, incorrect voltage applied to the unit at any time, damage or casualty. This warranty does not apply to any equipment failures related to poor water quality, excessive lime and chlorine and non-periodic cleaning and descaling. Warranty is null and void if muriatic or any other form of hydrochloric acid is used for cleaning or deliming. In addition, this warranty does not apply to replacement of items subject to normal use including but not limited to user replaceable parts such as faucet seat cups, sight gauge tubes, washers, o-rings, tubing, seals and gaskets.

This warranty is conditioned on the Buyer 1) giving Newco prompt notice of any claim to be made under this warranty by telephone at (800) 556-3926 or by writing to **3650 New Town Blvd, Saint Charles, MO 63301**; 2) if requested by Newco, shipping the defective equipment prepaid to an authorized Newco service location; and 3) receiving prior authorization from Newco that the defective equipment is under warranty.

THE FOREGOING WARRANTY IS EXCLUSIVE AND IS IN LIEU OF ANY OTHER WARRANTY, WRITTEN OR ORAL, EXPRESS OR IMPLIED, INCLUDING, BUT NOT LIMITED TO, ANY IMPLIED WARRANTY OF EITHER MERCHANTABILITY OR FITNESS FOR A PARTICULAR PURPOSE. The agents, dealers or employees of Newco are not authorized to make modifications to this warranty or to make additional warranties that are binding on Newco. Accordingly, statements by such individuals, whether oral or written, do not constitute warranties and should not be relied upon.

If Newco determines in its sole discretion that the equipment does not conform to the warranty, Newco, at its exclusive option while the equipment is under warranty, shall either 1) provide at no charge replacement parts and/or labor (during the applicable parts and labor warranty periods specified above) to repair the defective components, provided that this repair is done by a Newco Authorized Service Representative; or 2) shall replace the equipment or refund the purchase price for the equipment.

THE BUYER'S REMEDY AGAINST NEWCO FOR THE BREACH OF ANY OBLIGATION ARISING OUT OF THE SALE OF THIS EQUIPMENT, WHETHER DERIVED FROM WARRANTY OR OTHERWISE, SHALL BE LIMITED, AT NEWCO'S SOLE OPTION AS SPECIFIED HEREIN, TO REPAIR, REPLACEMENT OR REFUND.

In no event shall Newco be liable for any other damage or loss, including, but not limited to, lost profits, lost sales, loss of use of equipment, claims of Buyer's customers, cost of capital, cost of down time, cost of substitute equipment, facilities or services, or any other special, incidental or consequential damages.

**WARNING:** *Read and follow installation instructions before plugging or wiring in machine to electrical circuit. Warranty will be void if machine is connected to any voltage other than that specified on the serial tag. Machine must be plugged into a grounded outlet.*

# TABLE OF CONTENTS

Specifications -----	5
Warning Labels -----	6
Serial Tag -----	6
Electrical Specifications -----	7
Plumbing Specifications -----	7
Machine Set Up -----	8
Installing the Product BIBs -----	9
Machine Operation -----	10
How to Brew -----	10
Machine Programming -----	11
Programming Quick-Guide -----	11
Maintenance Menu -----	13
Setup Menu -----	14
Setup Menu – Drink Selection -----	15
Statistics Menu -----	16
Local Setup -----	16
Recipe Entry -----	17
Cleaning -----	19
Daily Cleaning Instructions -----	20
Cleaning and Priming the Pumps -----	20
Priming the Pumps -----	21
Servicing the Machine -----	22
Calibration Instructions -----	22
Machine Access Points -----	23
Draining the Hot Water Tank -----	25
Error Messages -----	26
Wiring Diagrams -----	27

# SPECIFICATIONS

## TEMPERATURE RANGE

140°F - 205°F

## CUP SIZE

6-20 oz.

## SHIPPING WEIGHT

38 lbs.

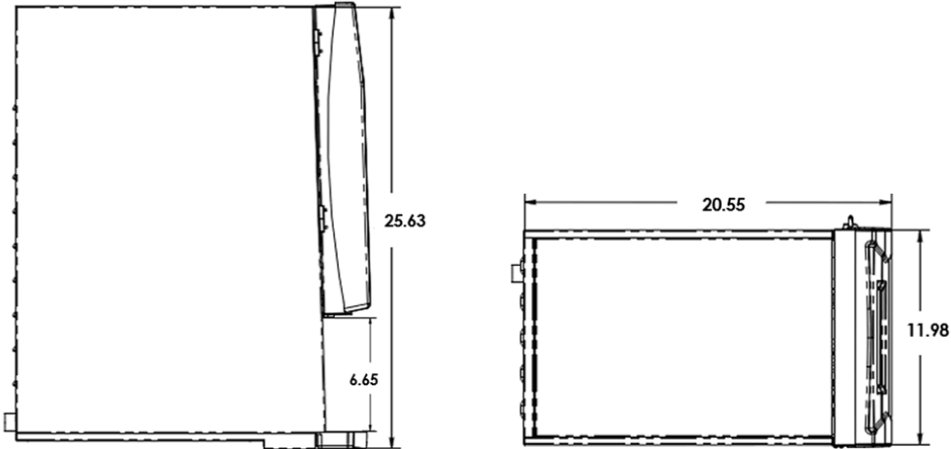

# BREWER FEATURES

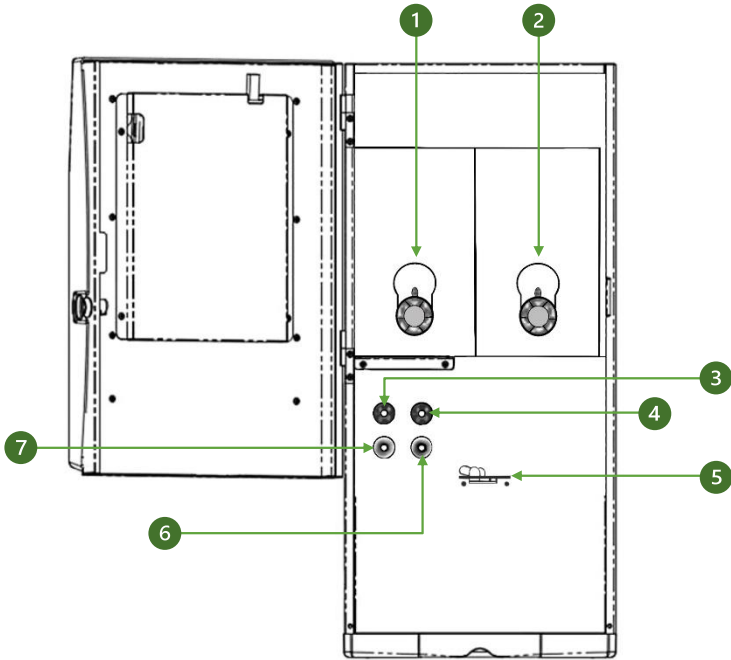

- 1. Liquid Coffee BIB – **REGULAR STRENGTH**
- 2. Liquid Coffee BIB – **DECAF**
- 3. Coffee Inlet – **REGULAR**
- 4. Coffee Inlet – **DECAF**
- 5. Product Dispense Nozzles
- 6. Coffee Outlet
- 7. Hot Water Outlet

- 8. Touch Screen Display
- 9. Drip Tray
- 10. Door Lock
- 11. Power Cord

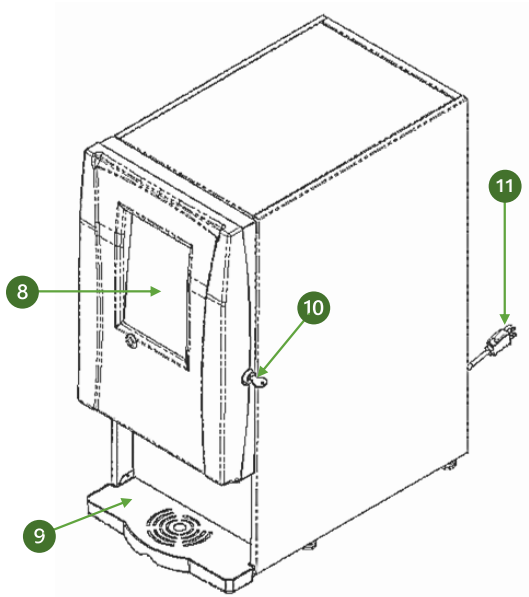

**Note:** Newco practices continuous product improvement. Product information and illustrations may vary from information contained in this guide.

# WARNING LABELS



1. Warning Label, Auto Faucet  
PN: 101025

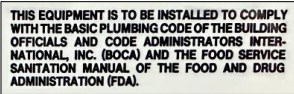

2. Label, Plumbing Instructions  
PN: 101012



3. Label, Backflow Prevention  
PN: 123062

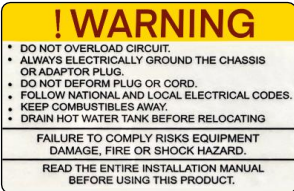

4. Warning Label, Precautions  
PN: 100817



5. Warning Label, Electric Shock  
PN: 100821

# SERIAL TAG



The Serial Tag is located on the **RIGHT-SIDE** outer panel. This label contains the following information:

- Electrical & circuit requirements
- Brewer model
- Brewer serial number
- MFG date

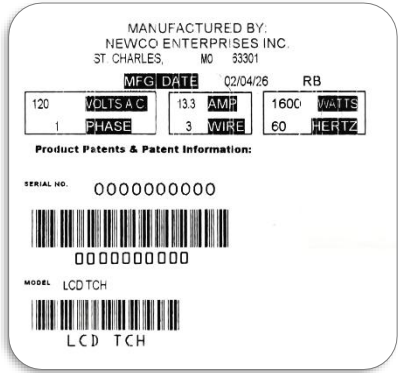

## ELECTRICAL SPECIFICATIONS



### **CAUTION:**

The brewer must remain disconnected from the power source until specified in Installation Instructions. Read all installation instructions **BEFORE** plugging in to electrical circuit.

**MACHINE MUST BE PLUGGED INTO A GROUNDED OUTLET!**



### **WARNING:**

Improper electrical installation will damage electronic components.

Warranty will be void if machine is connected to any voltage other than that specified on the Serial Tag.

Determine the available on-site electrical requirements.

Refer to Serial Tag on the brewer & local/national electrical codes to determine circuit requirements.

MODEL PN	VOLTS	WATTS	AMPS
PN: 122100	120 VAC	1600W	13.3A
PN: 122125	120 VAC	1750W	14.6A
PN: 122143	240 VAC	3500W	14.6A

Refer to Serial Tag for electrical & circuit requirements **BEFORE** plugging in brewer!

See pg. 6 for Serial Tag location

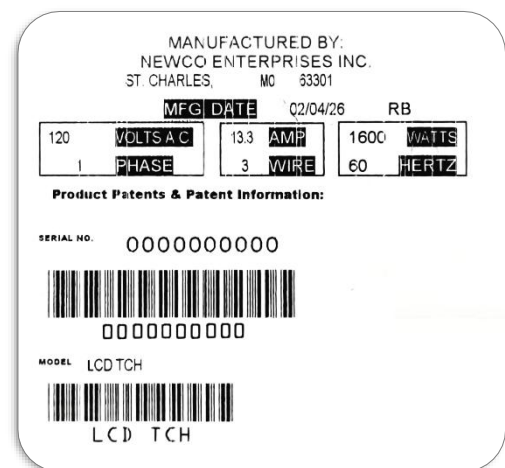

## PLUMBING SPECIFICATIONS

Always flush at least 1/2 gallon of water through the waterline to remove any debris.

This machine must be connected to a cold-water system with operating pressure between 20 and 90 psi (138 and 620 kPa) from a 1/2" or larger supply line. A shut-off valve should be installed in the line before the machine. Install a regulator in the line when pressure is greater than 60 psi (620 kPa) to reduce it to 50 psi (345 kPa). The water inlet fitting is 1/4" male flare.

A loose coil of copper tubing in the water line will allow movement of the machine to easily clean the countertop underneath.

**Note:** Water pressure should be at least 20 lbs. For less than a 25 ft run, use 1/4" copper tubing and connect to 1/2" or larger water line. For longer runs, use 3/8" copper tubing & connect to 1/2" or larger water line and provide an adapter fitting for connection to the brewer. Newco does not recommend the use of a saddle valve to install the brewer. The size and shape of the hole made in the supply line by this type of device may restrict water flow.

This equipment must be installed to comply with the Basic Plumbing Code of the Building Officials and Code Administrators International, Inc. (BOCA) and the Food Service Sanitation Manual of the Food and Drug Administration (FDA). For models installed outside the U.S.A., comply with the applicable Plumbing/ Sanitation Code.

# MACHINE SET UP



## WARNING:

Read all Set Up Instructions **BEFORE** plugging machine into electrical circuit.  
**Warranty will be void if machine is connected to any voltage other than that specified on the serial tag.**  
 Machine **must** be plugged into a grounded outlet.  
 Machine **must** be installed on a level surface.

1. Place brewer on a level countertop surface.
2. Connect the provided Strainer Assembly to Water Inlet.
  - a. The Water Inlet is located on the **back** of brewer, to the **left** of the power cord and power switch.
  - b. Place the white gasket inside of the plastic nut on Strainer Assembly **before** connecting it to Water Inlet.
  - c. Rotate plastic nut clockwise to secure the strainer assembly onto brewer inlet.

**2b.**  
 Gasket must be placed inside plastic nut **BEFORE** installing strainer onto brewer!

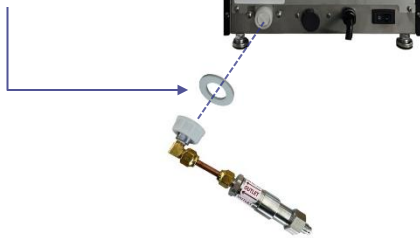

**2c.**  
 Rotate plastic nut clockwise to tighten down & secure Strainer Assembly to brewer.



3. Connect ¼ inch flare water supply to the Strainer Assembly.
4. Turn water supply on.
5. Plug brewer into the appropriate voltage circuit as indicated on the serial tag.
6. Turn brewer power on. Power switch is on the **back** of brewer to the **right** of the water inlet.
7. Upon initial power-on:
  - a. The display tablet will boot-up.
  - b. The brewer will begin filling the tank with water.  
**Note:** If the water in the tank has not filled to probe level within 4 minutes the brewer will enter an error mode & display an error alert.  
*See pg. 26 for error alert information.*
  - c. When the water reaches probe level, the tank will stop filling & begin heating.
  - d. When the water reaches temperature, the display will automatically change to the Main Menu.
8. Enter the Programming Menu to set desired parameters for brewer functions. Once parameters have been set, the brewer is operational / ready to use.

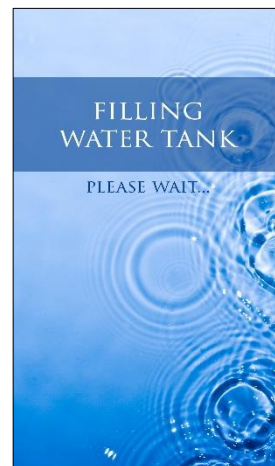

**7b.**

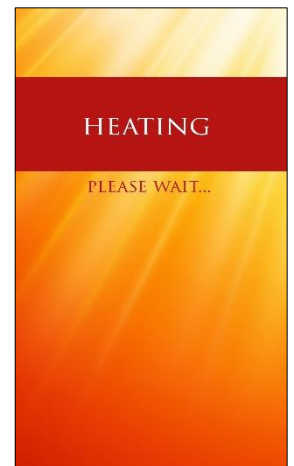

**7c.**

# MACHINE SET UP

## INSTALLING THE PRODUCT BIBs

For recipe accuracy, Coffee & Decaf product **MUST** be installed on designated side.

**A. LEFT SIDE:** Regular Coffee BIB

**B. RIGHT SIDE:** Decaf Coffee BIB

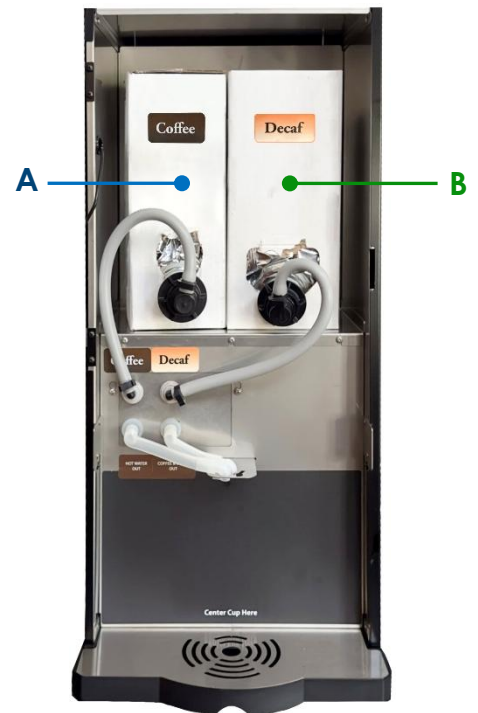

1. Open the cutout on the new product box & position the plastic BIB fixture into the slotted area.
2. Remove the plastic insert from the opening of BIB product fixture.
3. Open brewer cabinet to access product connector tubes. Thread the BIB connector from tube onto the BIB product fixture.
4. Rotate BIB connector clockwise **using finger & thumb only** (to prevent over-tightening.) Stop when BIB connector is fully seated against BIB product fixture.
5. Place the BIB in brewer cabinet.
6. Position the tubing upright & ensure that it is free of bends or twists.
7. Prime both pumps **BEFORE** dispensing beverages.

**Note:** Anytime a new BIB product is installed, the brewer pumps **MUST** be primed. See pg. 21 for detailed instructions.



1.



2.



3. & 4.



# MACHINE OPERATION

## HOW TO BREW

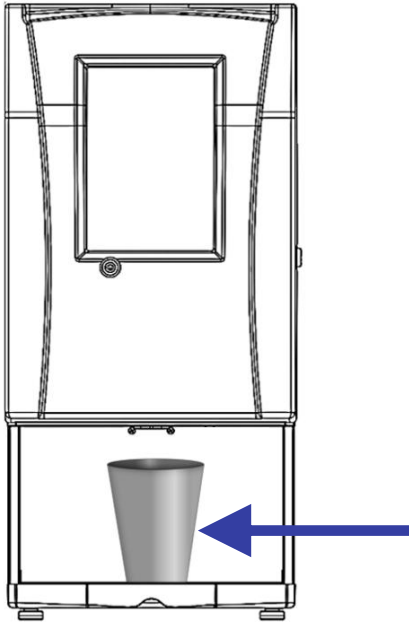

1. Place a cup below the dispense area.
2. Tap the icon for desired beverage on display screen.
  - a. For iced beverages, fill glass ¾ full of ice before placing below dispense area.
3. Brewer will display the submenu for selected drink. From this menu, set the following drink customizations:
  - a. Desired drink size
  - b. Desired brew strength
4. Touch the **'BREW'** icon. Drink will begin dispensing.



Tap icon for desired drink



### Drink Submenu Options

- |  |                                     |
|--|-------------------------------------|
| <b>A.</b> Cup Size<br>Tap (+) or (-) to adjust       | <b>C.</b> Return to Drink Selection |
| <b>B.</b> Drink Strength<br>Tap (+) or (-) to adjust | <b>D.</b> Begin brew cycle          |

# MACHINE PROGRAMMING

## PROGRAMMING QUICK-GUIDE

MENU		AVAILABLE OPTIONS	
<b>1</b>	<b>Enter Programming</b>	See pg. 12 for instructions on accessing brewer programming.	
<b>2</b>	<b>Maintenance</b>	<ul style="list-style-type: none"> <li>• Software Version</li> <li>• Board Version</li> </ul>	<ul style="list-style-type: none"> <li>• Water Filter Remaining</li> <li>• Water Filter Reset</li> </ul>
<b>3</b>	<b>Statistics</b>	<ul style="list-style-type: none"> <li>• Total Run Cycles</li> </ul>	<ul style="list-style-type: none"> <li>• Total Water Usage (<i>gal</i>)</li> </ul>
<b>4</b>	<b>Setup</b>	<ul style="list-style-type: none"> <li>• Water Temperature</li> <li>• Press and Hold</li> <li>• Energy Save Mode</li> <li>• Energy Save Time</li> <li>• Cup Light</li> <li>• Water Filter Size</li> </ul>	<ul style="list-style-type: none"> <li>• Global Ratio Reg</li> <li>• Global Ratio Decaf</li> <li>• Call For Service Number</li> <li>• Drink Selection Menu</li> <li>• Restore Factory Settings</li> </ul>
<b>5</b>	<b>Drink Selection</b>	<ul style="list-style-type: none"> <li>• Cup Configuration (<i>Small, Medium, Large</i>)</li> <li>• Mild Drink Enabled</li> <li>• Regular Drink Enabled</li> <li>• Bold Drink Enabled</li> </ul>	<ul style="list-style-type: none"> <li>• Iced Coffee Enabled</li> <li>• Espresso Enabled</li> <li>• Default Cup Size</li> <li>• Ounces Displayed</li> </ul>
<b>6</b>	<b>Calibration</b>	<ul style="list-style-type: none"> <li>• Water Cal Oz.</li> </ul>	
<b>7</b>	<b>Recipe Entry</b>	<ul style="list-style-type: none"> <li>• Recipe Name</li> <li>• Recipe Number</li> <li>• Recipe Type</li> </ul>	<ul style="list-style-type: none"> <li>• Peri Pretime</li> <li>• Water Volume</li> <li>• Pump Strength</li> </ul>
<b>8</b>	<b>Local Setup</b>	<ul style="list-style-type: none"> <li>• Sleep Timeout</li> </ul>	<ul style="list-style-type: none"> <li>• Brewing Screen</li> </ul>

# MACHINE PROGRAMMING

## Accessing Lower Level Programming

The Lower Level Programming menu offers options to adjust brewer settings and view brewer statistics. To enter the lower level programming, tap **3x** in the center of the 'D' in 'LCD'.

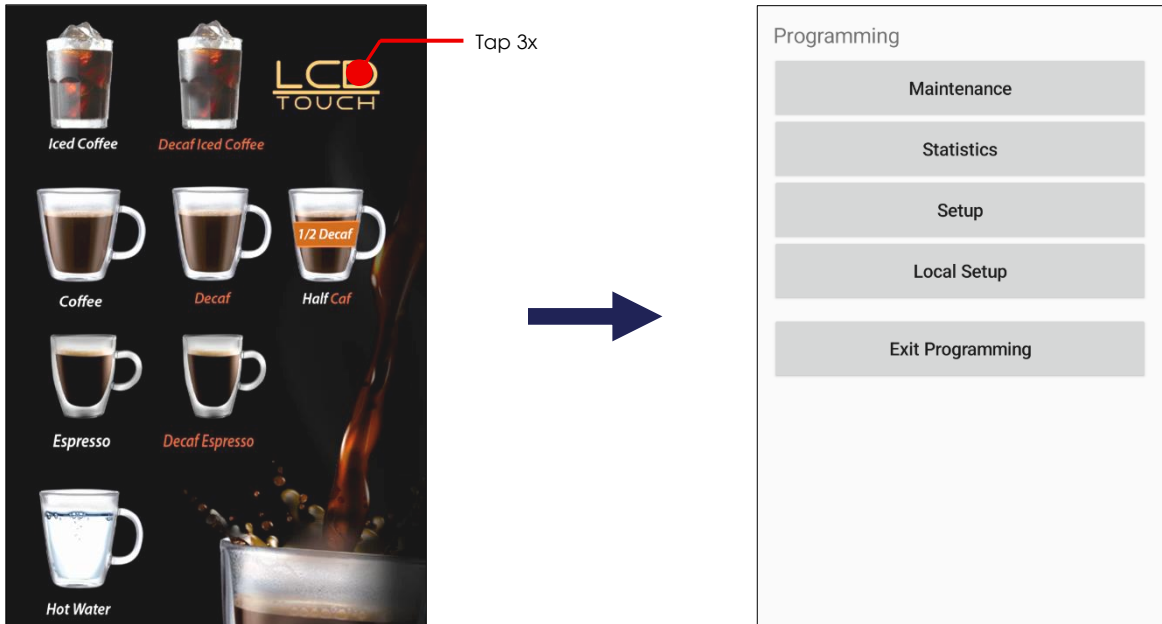

## Accessing Upper Level Programming

The Upper Level Programming menu includes options to calibrate your machine and edit recipes. To enter the upper level programming:

1. Tap **3x** in the center of the 'L' (circled in red)
2. Tap **3x** in the center of the 'D' (circled in blue)

**Note:** If a brewing icon is accidentally touched, use the back arrow to return to the Drink Selection Menu.



# MACHINE PROGRAMMING MAINTENANCE MENU

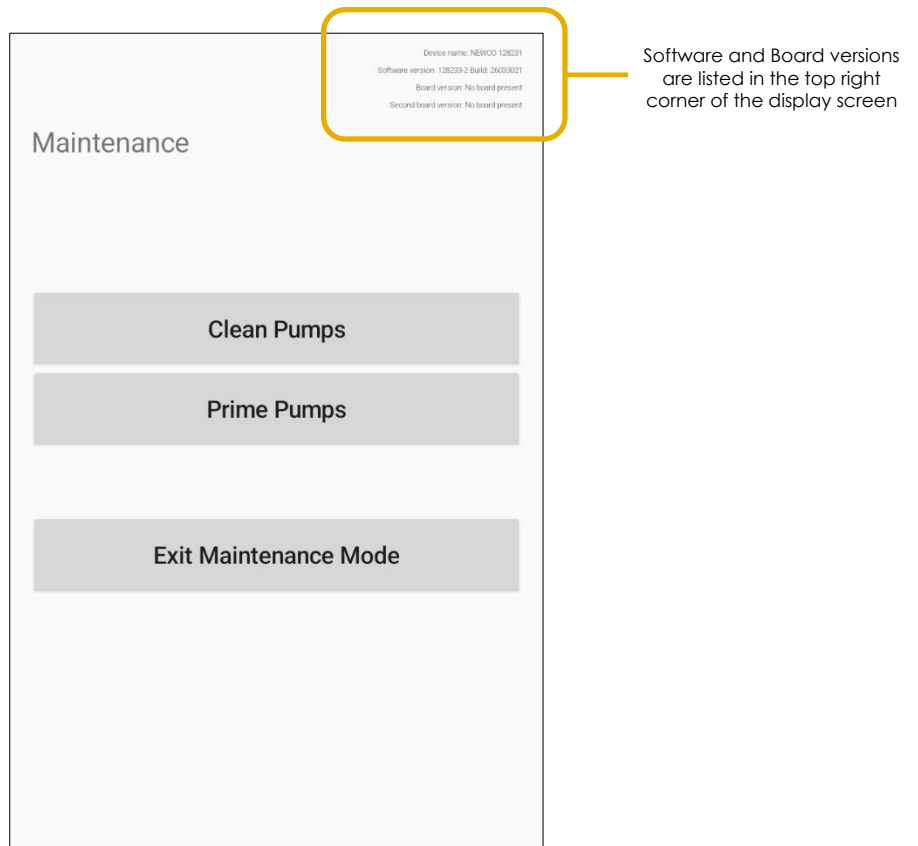

*Software & firmware versions listed in this image are for display purposes only & may vary from the version running on your machine  
Always refer to the Maintenance Menu within your specific brewer when inquiring about software or firmware versions*

## 1. Software Version

Indicates the version of software that the brewer tablet is running.

### Board Version

Indicates the version of software that the main board is running.

## 2. Water Filter Remaining Gal

Displays the remaining water filter gallons left before the filter needs to be changed.

## 3. Water Filter Reset

Select this after changing filters to reset water filter countdown. This field will only display when a water filter size is set in the Setup Menu.

# MACHINE PROGRAMMING

## SETUP MENU

### To Edit a Setting:

Tap desired field to highlight, then use the (+) or (-) to adjust value. Press “Exit Setup Mode” when finished to save changes.

Setup			
Water Temperature	180	Press And Hold	OFF
Energy Save Mode	OFF	Energy Save Time	4.0
Global Ratio Reg	30	Cup Light	DISPENSE ONLY
Global Ratio Decaf	30	Water Filter Size	OFF
Call for Service Number		1-800-556-3982	
+		-	
Drink Selection Menu			
Restore Factory Settings			
Exit Setup Mode			

### 1. Water Temperature

Displays the set temperature of water in the hot water tank.

**Range:** 170°F – 205°F

**Default:** 180°F

### 2. Press and Hold

Enables 'Press and Hold' for coffee selections.

### 3. Energy Save Mode

**OFF:** The brewer will continuously maintain the set temperature of the water in the hot water tank.

**SEMI:** The set point of water in the hot water tank is reduced to 180°F until interaction is detected.

**FULL:** The heater in the hot water tank is disabled until the brewer detects any interaction.

### 4. Energy Save Time

Use to adjust the amount of time (from last dispense) until the brewer enters the chosen Energy Save Mode.

**Note:** This setting will not take effect if Energy Save Mode is set to OFF.

### 5. Cup Light

**OFF:** The cup light is disabled.

**DISPENSE ONLY:** The cup light will only turn on when the brewer is actively dispensing a beverage.

**ALWAYS ON:** The cup light is always on.

### 6. Global Ratio Reg / Global Ratio Decaf

Sets the Coffee to Water Ratio across all applicable recipes.

**Range:** 25:1 – 45:1

**Default:** 30:1

### 7. Water Filter Size

Turn water filter tracking on/off. If water filter size is set, the Water Filter Remaining count is viewable in the Maintenance Menu.

**Range:** 500 gal – 3000 gal, OFF

See pg. 13 for more information on the Maintenance Menu.

### 8. Call for Service Number

Enter the contact number for your brewer service/maintenance provider. This number will display whenever the brewer displays an error message.

### 9. Drink Selection Menu

Tap to enter the Drink Selection Menu. See pg. 15 for more information.

### 10. Restore Factory Settings

Touch to reset all settings to the factory default.

# MACHINE PROGRAMMING

## SETUP MENU

### Drink Selection Menu

**Drink Selection Menu**

Small Cup Config	8 oz	Mild Drink Enabled	ON
Medium Cup Config	10 oz	Regular Drink Enabled	ON
Large Cup Config	12 oz	Bold Drink Enabled	ON
Iced Coffee Enabled	ON	Default Cup Size	MED
Espresso Enabled	ON	Ounces Displayed	OFF

+

-

Exit Drink Selection Menu

#### 1. [SMALL] [MEDIUM] [LARGE] Cup Config

Set to **OFF** to disable a specific drink size option in the Beverage Submenu.

#### 2. [MILD] [REGULAR] [BOLD] Drink Enabled

Set to **OFF** to disable a specific brew strength option in the Beverage Submenu.

#### 3. Iced Coffee Enabled

Set to **OFF** to disable all Iced Coffee drink selections. When disabled, the Iced Coffee icon will no longer display on the Main Beverage Selection Screen.

#### 4. Espresso Enabled

Set to **OFF** to disable the 'Espresso' option. When disabled, the Espresso icon will no longer display on the Main Beverage Selection Screen.

#### 5. Default Cup Size

Sets the default drink size displayed when a beverage selection submenu is accessed.

**Note:** Default cup Size must have a set size. If this Option is set to '**OFF**', operator will not be able to exit the Drink Selection Menu.

#### 6. Ounces Displayed

**OFF:** [SMALL] [MED] [LARGE] options will display on the Drink Selection Submenu

**ON:** Drink size in ounces will display on the Drink Selection Submenu

# MACHINE PROGRAMMING

## STATISTICS MENU

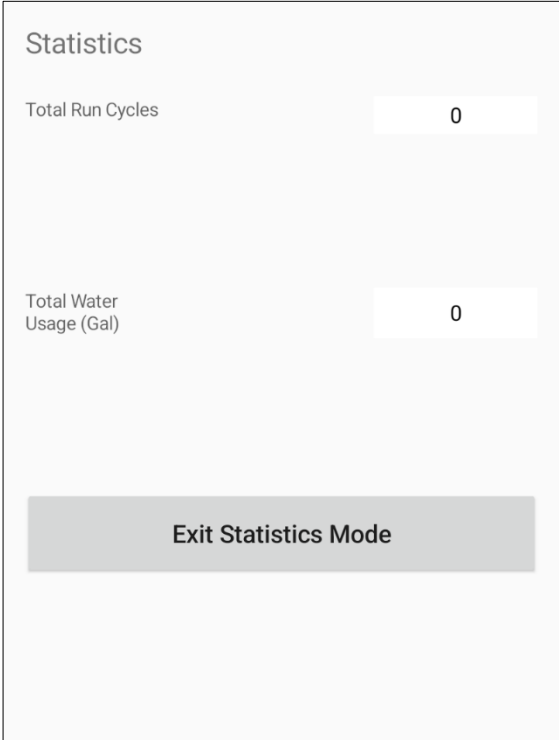

### 1. Total Run Cycles

Displays the total number of drinks dispensed by the brewer

### 2. Total Water Usage (Gal)

Displays the total amount of water dispensed by the brewer (*in gallons*)

## LOCAL SETUP

### 1. Sleep Timeout

Displays the amount of time (*in minutes*) that the main brewer display will stay up between interactions. When the time limit is reached, the display will change to a sleep screen.

### 2. Brewing Screen

**DFLT:** Newco standard slates display when a drink is brewing.  
**LOGO:** The brewer logo displays when a drink is brewing.

### 3. Network Setup

For future use.

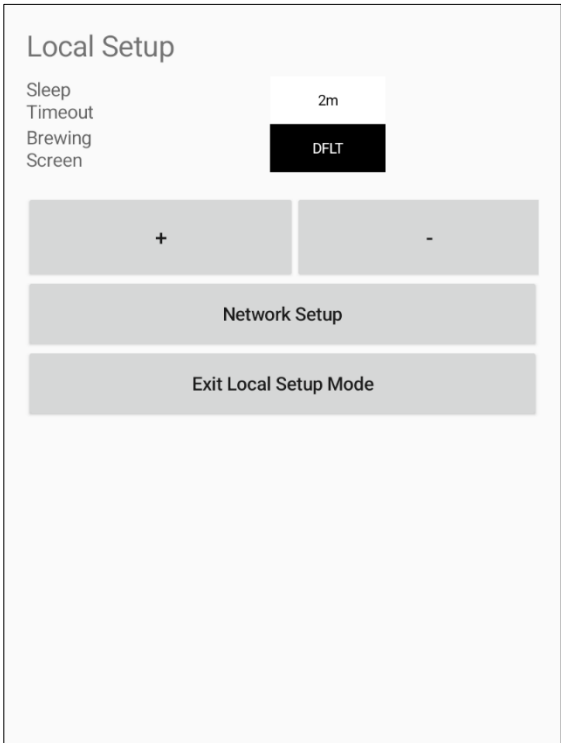

# MACHINE PROGRAMMING

## RECIPE ENTRY

**Recipe Entry**

Recipe Name	Coffee 20oz Reg		
Recipe Number	16	Recipe Type	1
Peri Pretime	15	Water Vol	184
Pump Strength	80		

+

-

Save Recipe

Exit Recipe Entry

### 1. Recipe Name / Recipe Number / Recipe Type

Touch the **Recipe Number** field to highlight. Use the **(+)** or **(-)** to scroll through pre-programmed recipes. See pg. 18 for a complete list of pre-programmed recipes

### 2. Peri Pretime

Sets the length of time that the pump runs when pulling product from the coffee BIBs.

**Range: 0 - 200**

### 3. Water Volume

Sets the amount of water to be mixed with the BIB coffee concentrate for a recipe.

Adjusting this setting affects the Coffee to Water Ratio / brew strength.

**Range: 5 - 200**

### 4. Pump Strength

Sets the DC pump strength for a specific recipe.

**Range: 20% - 100%**

**User must touch 'Save Recipe' before exiting for recipe customizations to save!**

# MACHINE PROGRAMMING

## RECIPE ENTRY

### Recipe List

The following chart displays the name and number of all pre-programmed recipes.

0	Coffee 6oz Mild	13	Coffee 16oz Reg	26	Iced Coffee 10oz Bold
1	Coffee 6oz Reg	14	Coffee 16oz Bold	27	Iced Coffee 12oz Mild
2	Coffee 6oz Bold	15	Coffee 20oz Mild	28	Iced Coffee 12oz Reg
3	Coffee 8oz Mild	16	Coffee 20oz Reg	29	Iced Coffee 12oz Bold
4	Coffee 8oz Reg	17	Coffee 20oz Bold	30	Iced Coffee 16oz Mild
5	Coffee 8oz Bold	18	Iced Coffee 6oz Mild	31	Iced Coffee 16oz Reg
6	Coffee 10oz Mild	19	Iced Coffee 6oz Reg	32	Iced Coffee 16oz Bold
7	Coffee 10oz Reg	20	Iced Coffee 6oz Bold	33	Iced Coffee 20oz Mild
8	Coffee 10oz Bold	21	Iced Coffee 8oz Mild	34	Iced Coffee 20oz Reg
9	Coffee 12oz Mild	22	Iced Coffee 8oz Reg	35	Iced Coffee 20oz Bold
10	Coffee 12oz Reg	23	Iced Coffee 8oz Bold	36	Espresso Shot Single
11	Coffee 12oz Bold	24	Iced Coffee 10oz Mild	37	Espresso Shot Double
12	Coffee 16oz Mild	25	Iced Coffee 10oz Reg	38	Espresso Shot Triple

# CLEANING

## DAILY CLEANING INSTRUCTIONS

1. Wipe brewer down with a damp cloth to remove any residue.
2. Remove drip tray & empty contents. Hand wash drip tray components.  
**Note:** Drip Tray is **NOT** dishwasher safe!

## CLEANING AND PRIMING THE PUMPS

1. Place an empty cup (capable of holding at least 12oz) under the dispense area.
2. Access the Cleaning Menu:
  - a. Touch & hold in the bottom right corner of the display screen for approx. five seconds.
  - b. Release touch. Shortcut icons for the Clean & Prime menus will appear in the lower left/right corners.
  - c. Tap the '**Clean**' icon (left side.) The Cleaning Menu will appear on the display.



2a.

Press & hold for approx. 5 seconds, then release



2c.

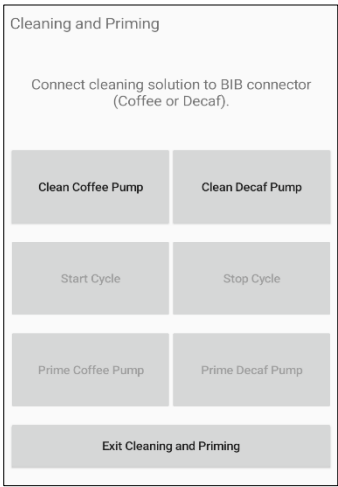

3. Open brewer cabinet & disconnect the connection tube from the Regular Coffee BIB product (left-side.)
4. Connect the tube to a BIB of cleaning solution.



3.

Disconnect tube from the left-side regular coffee product



4.

Connect tube to BIB cleaning solution

# CLEANING

## CLEANING AND PRIMING THE PUMPS *(continued)*

- 5. Place an empty cup (capable of holding at least 16oz) under the dispense area.
- 6. Touch 'Clean Coffee Pump'.
- 7. Touch 'Start Cycle'. The cleaning cycle will start & finish automatically. Cleaning cycle runs for approx. 2.5 minutes.
- 8. When the cleaning cycle ends, disconnect the cleaning solution from BIB connector and reconnect the Coffee-side connection tube to coffee product.
- 9. The brewer will automatically prompt user to prime the pump once the cleaning cycle ends.  
**PUMP MUST BE PRIMED AFTER RUNNING A CLEANING CYCLE!**
- 10. Discard contents in cup from the cleaning cycle & replace cup in dispense area.
- 11. Touch & hold 'Prime Coffee Pump'. Liquid will begin dispensing into cup.
- 12. Release 'Prime Coffee' button once cup is full. Discard contents.
- 13. Touch 'Exit Cleaning and Priming' to return to the main beverage selection menu.
- 14. Repeat steps 1 – 12 to clean the right-side Decaf Coffee Pump.



**! DO NOT USE A STYROFOAM VESSEL TO COLLECT CLEANING SOLUTION!**

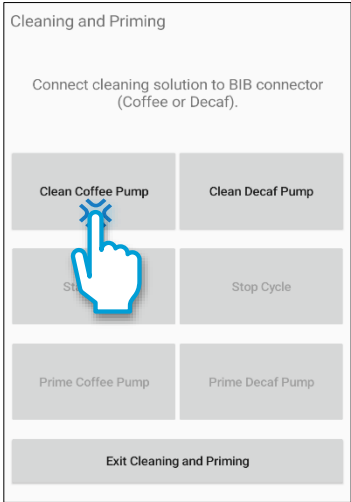

6.

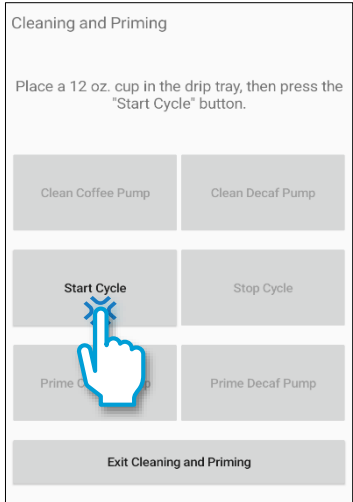

7.



8.  
Reconnect coffee tube to BIB coffee product

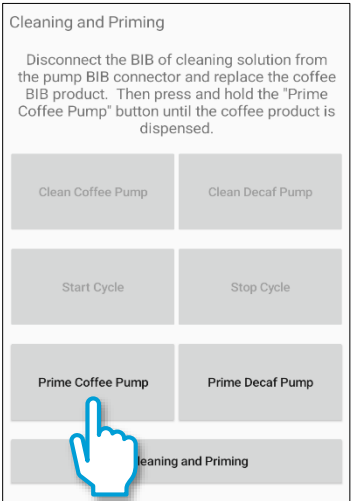

11.

# CLEANING INSTRUCTIONS

## CLEANING AND PRIMING THE PUMPS

### Priming the Pumps

To prime the pumps **without running a cleaning cycle**, perform the following steps:

1. Place an empty 16oz cup under the dispense area.
2. Access the Cleaning and Priming menu:
  - a. Touch & hold the empty space to the **RIGHT** of the hot water icon for approx. five seconds.
  - b. Release screen. Shortcut icons for '**Clean**' and '**Prime**' will appear in the lower left/right corners.
  - c. Tap the '**Prime**' icon (*right-side*) to enter the Cleaning and Priming menu.
3. Touch & hold the '**Prime**' button for intended pump. Liquid will begin dispensing into cup.
4. Release '**Prime**' button once cup is full. Discard contents.
5. Tap '**Exit Cleaning and Priming**' to return to the main beverage selection menu.

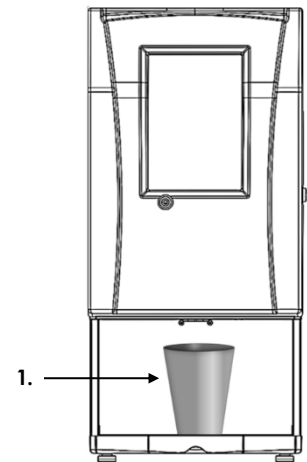

2b.

Touch & hold for approx. 5 seconds, then release



2c.

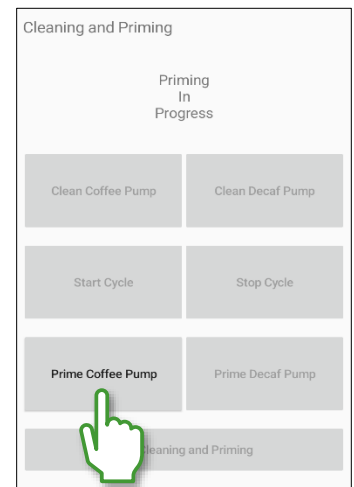

3.

### Flush Products and Fittings

The following brewer cleaning / flushing products are available for purchase through Newco.



**Easy Clean Solution**  
PN: 900083



Product shown removed from box



**Scholle Fitting**  
(for connection tubes)  
PN: 107117

# SERVICING THE MACHINE

## CALIBRATION INSTRUCTIONS

**WARNING:**  
 Read all instructions thoroughly **BEFORE** servicing brewer!  
 Improper calibration procedures may affect product dispense ratios & negatively impact brewed drink flavor.

### Accessing the Calibration Menu

Enter the Calibration Menu by accessing **Upper Level Programming** and selecting '**Calibration**'.  
*(see pg. 12 for more information on accessing upper level programming)*

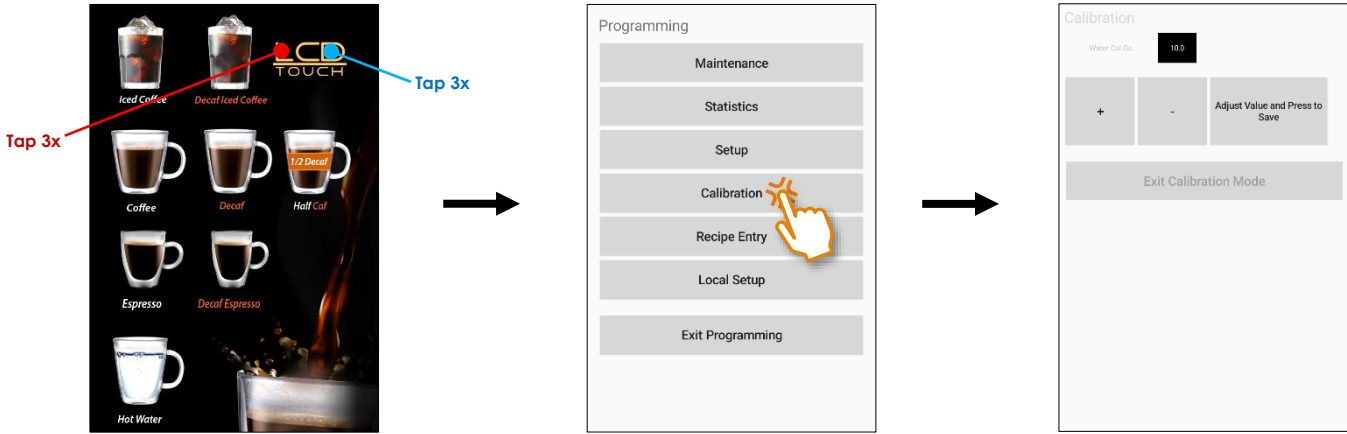

Tap **3x** in the center of the letter 'L', then **3x** in the center of the letter 'D' to access Upper Level Programming

## 1. Coffee Valve Calibration / Water Cal. Oz

### Required Supplies:

- Food Scale
  - Large pitcher for collecting liquid (*capable of holding at least 30 fl. oz*)
- a. Place a large pitcher onto a food scale and tare (*ounces*)
  - b. Place the tared pitcher onto brewer below the dispense area.  
**Note:** Remove drip tray if pitcher is too large.
  - c. Tap the '**Water Cal Oz.**' field to highlight.
  - d. Tap '**Start Cal Cycle**'. Water will begin dispensing into pitcher.
  - e. Once cycle completes, weigh the contents of the pitcher in ounces.
  - f. Input weight into highlighted field using the **(+)** and **(-)**. Save value when finished.

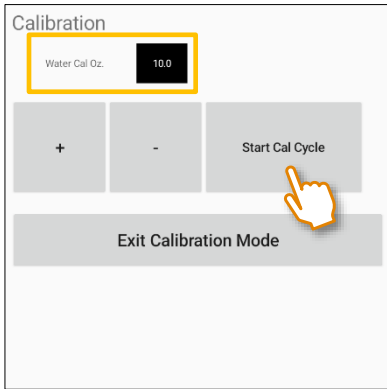
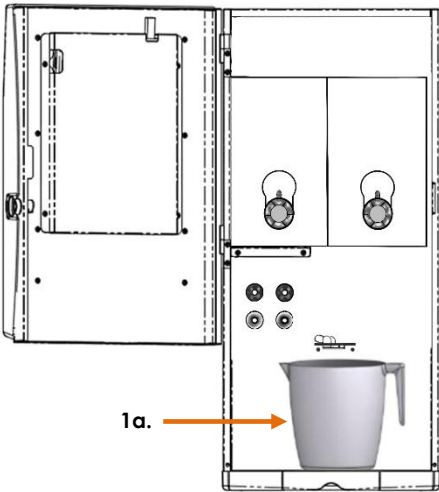

1c. & 1d.

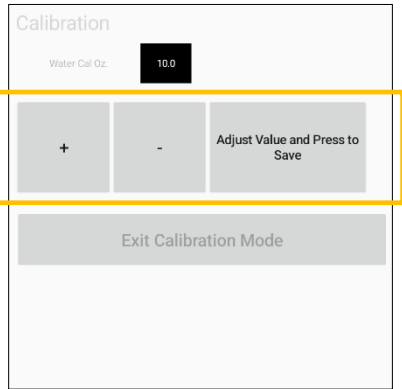

1f.

# SERVICING THE MACHINE

## MACHINE ACCESS POINTS



### **WARNING:**

Toggle brewer power **OFF** and disconnect from power source **BEFORE** removing panels!

### 1. Pump Access

To access the pumps:

- Toggle brewer power **OFF** and disconnect from power source.
- Open brewer cabinet door.
- Disconnect and remove both BIB products from cabinet.
- Use a Phillips Head screwdriver to partially unscrew the **(3x)** screws (*circled*) from the panel above the whipper assembly. **DO NOT FULLY REMOVE SCREWS!**
- Lift panel upward to clear screws. Remove panel from brewer cabinet and set aside.



1d.

### 2. Back Panel

Remove the Back Panel to access to the following components:

- Power switch & power cord
- Power cord
- Hot water tank
- Transformer
- Fan assembly
- Auxiliary board
- Tablet power supply & cord

To remove the back panel:

- Toggle brewer power **OFF** and disconnect from power source.
- Use a Phillips Head screwdriver to remove the **(4x)** screws (*circled*) from the back panel. Set screws aside.
- Use a Phillips head screwdriver to remove the **LOWER RIGHT** screw from the fan assembly. Set screw aside.
- Remove panel & set aside.



2b. & 2c.

# SERVICING THE MACHINE

## MACHINE ACCESS POINTS



### **WARNING:**

Toggle brewer power **OFF** and disconnect from power source **BEFORE** removing panels!

### 3. Side Panel

Remove the side panels to access the following components:

#### **RIGHT SIDE PANEL**

- Main control board bracket

#### **LEFT SIDE PANEL**

- Blower motor

To remove the side panel:

- Toggle brewer power **OFF** & disconnect from power source.
- Remove drip tray assembly & set aside.
- BACK OF BREWER:**  
Use a Phillips Head screwdriver to remove (1x) screw (circled) from side panel. Set screw aside.
- FRONT OF BREWER:**  
Use a Phillips Head screwdriver to remove (1x) screw (circled) from side panel. Set screw aside.
- Remove side panel & set aside.



3c.



3d.

### 4. Main Control Board Bracket

To access the main control board:

- Toggle brewer power **OFF** & disconnect from power source.
- Remove the **LEFT SIDE PANEL** from brewer. See previous instruction set for process steps.
- Partially unscrew the (2x) screws on the main control board bracket. **DO NOT FULLY REMOVE SCREWS!**
- Lift bracket upward to clear screws.

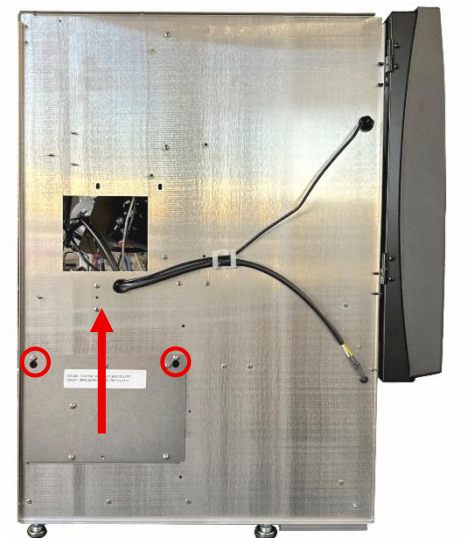

4c.

# SERVICING THE MACHINE

## DRAINING THE HOT WATER TANK



**WARNING:**

Disconnect brewer from power & allow hot water to cool completely before attempting to drain water tank!

1. Toggle brewer power switch **OFF** & disconnect machine from power source.  
**Note:** Give ample time for hot water in tank to cool before beginning process!
2. Locate the tank drain plug at the bottom of the brewer back panel.
3. Gently pull on the plug & extend the drain tube out from brewer compartment.  
**Note:** The drain tube has a clamp attached.
4. Remove the drain plug from the end of the drain tube.
5. Direct drain tube into a container or drain. Ensure your hands are away from the end of the tube.
6. Slide the tube clamp to release the water.
7. Once the water has finished draining, slide the clamp back to close off the drain tube.
8. Insert the drain plug onto the end of the drain tube.
9. Push the drain tube back into the machine & push the drain plug back into its opening.



2. Locate drain plug



3. Pull drain plug & extend drain tube out



5. Direct tube into a container or drain **BEFORE** sliding clamp!



6. Slide tube clamp to release water.

**CAUTION!**  
Released water may be hot!  
Keep hands away from drain tube opening.

# SERVICING THE MACHINE

## ERROR MESSAGES

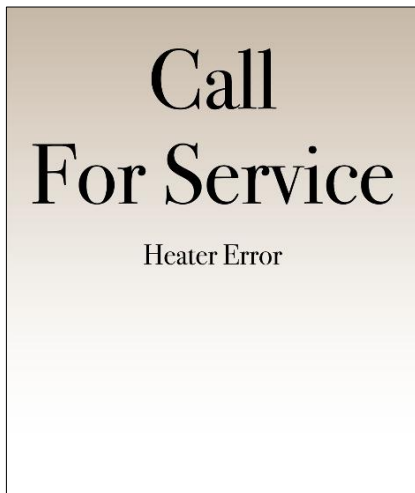

An Error Message will appear on the display screen if the brewer encounters an issue during the brew cycle.

The Error Message includes a description of the error and a message to call for service.

If a Call for Service number is entered in the Setup Menu, that number will also appear on the error message screen.

DESCRIPTION	POSSIBLE CAUSE	REMEDY
<b>Fill Time Out Error</b>	Water supply is shut off to machine	Check water supply shutoff
	Supply line is blocked or too small	Repair or replace as needed
	Water filter restricted	Replace water filter
	Inlet solenoid valve is faulty	Replace inlet valve - <b>SERVICE REQUIRED</b> <b>Inlet Valve PN: 201175</b>
	Control board failure	Replace Control Board - <b>SERVICE REQUIRED</b> <b>Control Board PN: 128247</b>
<b>Heater Error</b>	Reset thermistor	Perform a manual reset of the thermistor
	Faulty tank element	Replace tank element - <b>SERVICE REQUIRED</b> <b>Tank Element PN: 120928-10</b>
	Control board failure	Replace control board - <b>SERVICE REQUIRED</b> <b>Control Board PN: 128247</b>
<b>Overheat Error</b>	Faulty thermistor	Replace thermistor <b>PN: 111593</b>
	Faulty relay	Replace relay <b>Relay PN: 122091</b>
	Control board failure	Replace control board - <b>SERVICE REQUIRED</b> <b>Control Board PN: 128249</b>
<b>Thermistor Error Short</b>	Thermistor not plugged in	Ensure all thermistor connections are secure.
	Faulty thermistor	Replace thermistor <b>Thermistor PN: 111593</b>
	Control board failure	Replace control board - <b>SERVICE REQUIRED</b> <b>Control Board PN: 128249</b>
<b>Thermistor Error Open</b>	Thermistor not plugged in	Ensure all thermistor connections are secure.
	Faulty thermistor	Replace thermistor <b>Thermistor PN: 111593</b>
	Control board failure	Replace control board - <b>SERVICE REQUIRED</b> <b>Control Board PN: 128247</b>

# WIRING DIAGRAM

Wire colors subject to change based on availability.

## 120VAC

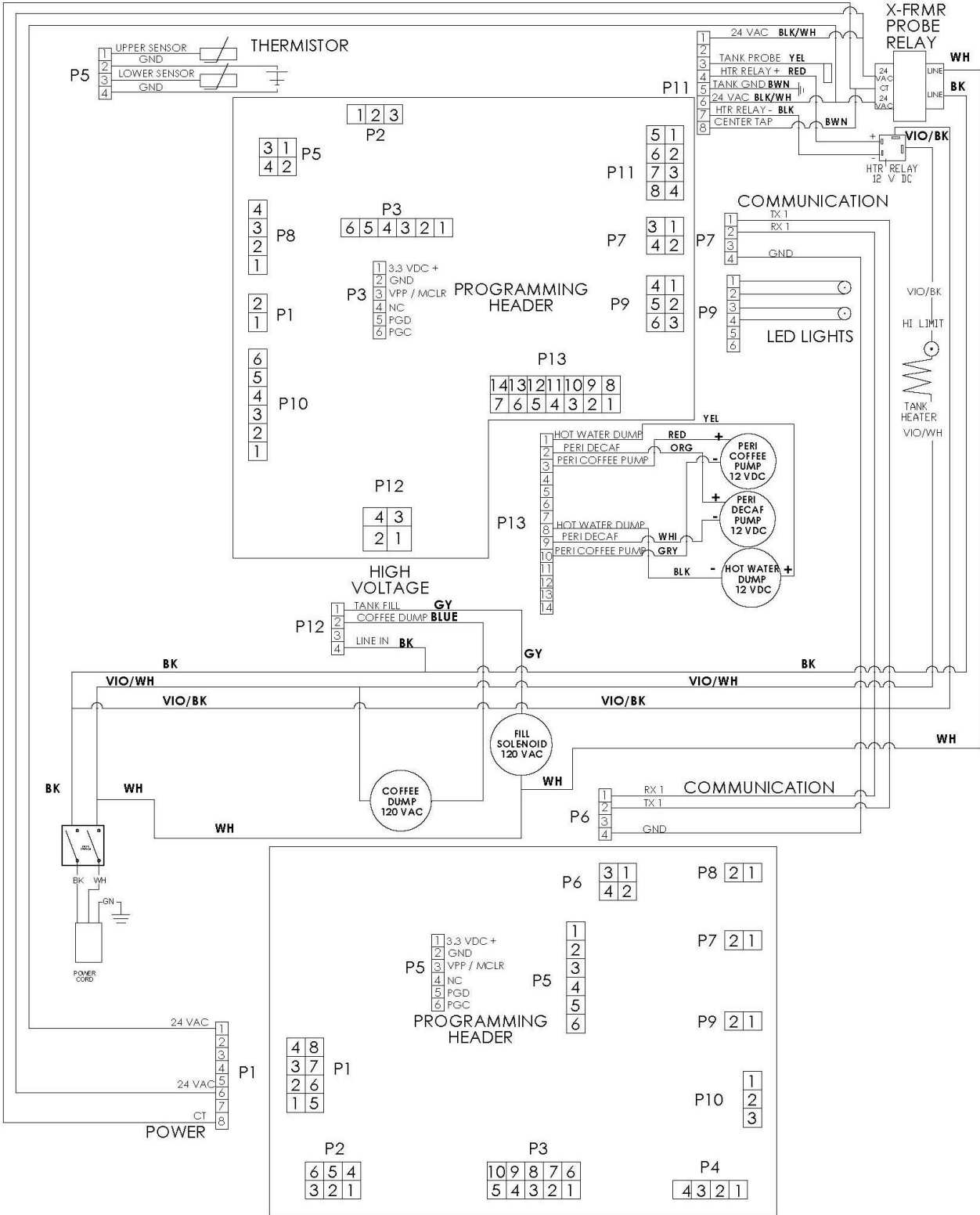

# WIRING DIAGRAM

Wire colors subject to change based on availability.

## 240VAC

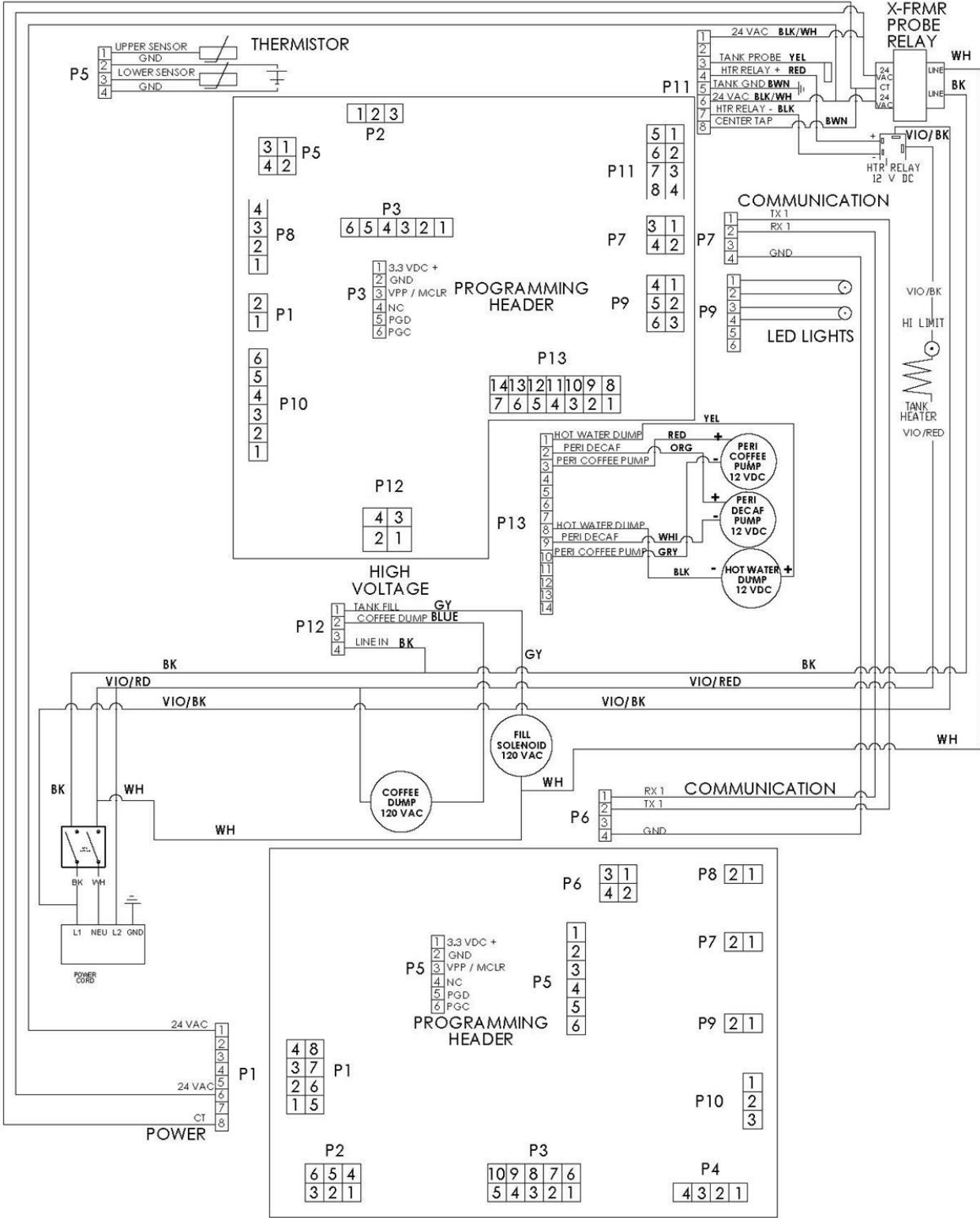

***Page intentionally left blank.***

***Page intentionally left blank.***

***Page intentionally left blank.***

